

Certification organization



1, rue du Général Leclerc
92800 Puteaux
Tel. : +33 1 80 21 07 40
Fax: +33 1 46 37 19 55
infocertigaz@certigaz.fr
www.certigaz.fr

Mandated by



11 rue Francis de Pressensé
F - 93571 La Plaine Saint Denis Cedex

Identification number: NF540

Revision number: 11

Date of application:

Certification rules for the NF RAC-GAZ mark (1)



The **NF540 (NF RAC-GAZ)** is applicable on :

- interchangeable connectors
- assembled connection sets
- gas appliance connection kits
- sealing materials for threaded connections
- elastomeric materials for seals and membranes for gas installations



(1) *the NF mark reference system is made up of the Specific Rules for certification of the mark concerned and in annexes the General Rules of the NF mark and the normative documents referenced therein.*

SUMMARY

PART 1: PRESENTATION AND SCOPE	5
1.1 Scope	5
1.2 Products and product ranges	6
1.3 Who can apply for the NF mark and why?	9
1.4 The NF mark	9
PART 2: THE REQUIREMENTS OF THE REFERENCE	11
2.1 The certification framework	11
2.2 Additional standards and specifications	11
2.3 Regulations	14
2.4 Quality management clauses	14
2.5 Marking	22
PART 3: GETTING CERTIFIED	27
3.1 Submission of a certification application file	29
3.2 Instruction of the request / admissibility	29
3.3 Control methods	30
3.4 Evaluation and decision	39
PART 4: MAKING CERTIFICATION LIVE: monitoring methods	41
4.1 Monitoring methods	41
4.2 Evaluation and decision	42
4.3 Declaration of modifications	43
4.4 Conditions for stopping marking or demarking	44
PART 5: STAKEHOLDERS	45
5.1 AFNOR Certification	45
5.2 CERTIGAZ	45
5.3 Inspection and audit organizations	45
5.4 Laboratories	45
5.5 Special committee	46
PART 6: THE RATES	48
6.1 Services relating to certification.....	48
6.2 Recovery of services	50
6.3 Amount of services	50
PART 7: CERTIFICATION FILES	51
7.1 Right to use application files	51
7.2 Form models	52
PART 8: GLOSSARY	61

These Certification Rules have been submitted for approval to AFNOR Certification for acceptance into the NF certification system. They were approved by the legal representative of AFNOR Certification on 05/23/2024.

They cancel and replace any previous version.

These Certification Rules are applicable on the date of approval. There is no implementation deadline for the elements that have been subject to changes to these Rules, unless indicated by a transitional period defined in the summary table of modifications.

The Certification Rules may be revised, in whole or in part, by CERTIGAZ and after consultation with the Specific Committee of the NF RAC-GAZ mark .

The revision is approved by the legal representative of AFNOR Certification, for acceptance into the NF certification system.

This standard is available and downloadable from the website www.certigaz.fr or www.marque-nf.com

Other information relating to certification and certified products is available on these websites, including:

- identification of holders;
- identification of certified products;
- the list of certified characteristics.

In litigation, the French version applies

CHANGE HISTORY

no .	Date	Changes made	Date of application of the evolution (1)
5	03/12/21	Integration of gas appliance connection kits from CCH2020-02	Immediate no impact on certified products
		§1.1.2, §2.4.4.8 and §3.3.2: addition of socket deformation conditions (captive nut)	
		§1.2.1: addition of certification of fittings with mechanical link	
		§2.2.1: addition of the M20x150 "cap" shape according to standard NF M 88-781	
		§2.5.3.1: addition of conditions for NF marking on products: wired logo and use of NF letters	
		§3.3.2: addition of conditions for lifting deviations on site	
6	04/19/21	Addition of COFRAC logo following accreditation of the NF540 mark	Immediate no impact on certified products
		Part 8: Glossary: modification of the definitions of major and minor non-conformities	
7	06/10/21	§2.4.1: removal of the reference to the 2008 version of ISO 9001	Immediate no impact on certified products
		§2.5.5: Change of dates of application for remarking operations of products in stock with the holder (cases no. 1 and no. 2)	
		§2.5.5: Elimination of case no. 3: observation of stocks present at the holder's customers	
8	05/01/22	§2.2.3: "Foundry fittings": addition of grade CC757S	Immediate no impact on certified products
		§2.2.3: Addition of the paragraph "NF D 36-136 – For the G3/4 LPG line connection" with diagram	
		§2.5.5: Modification of the "Marking of products in stock during certification in order to only deal with gas appliance connection kits Elimination of case no. 2	
		Part 3: General: addition of conditions for maintaining the NF mark	
		§3.3.2: Audit: addition of conditions for audits to maintain the NF mark	
		§3.3.2: "Exceptional exemption procedure linked to the Covid 19 pandemic": withdrawal possibility of remote admission audit + maintenance of remote surveillance audit under conditions	
		§7.2: withdrawal model letter 007	

9	06/16/22	Rules header and request letters (part 7): change of Certigaz address	Immediate: no certified products
		Page 3: addition "... unless indicated by a transitional period defined in the summary table of modifications" and the § "Other information relating to certification..."	
		§1.1: Addition of prefabricated fittings and definitions	
		§1.2.2: Addition of prefabricated brazed and brazed fittings	
		§2.2.1: Addition ATG B600	
		§2.2.3: Added requirements for ATG B600: reading § 10.1.3	
		§2.4.4.8: Addition of standard control plan table for ATG B600 fittings	
		§2.4.4.9: Addition of paragraph for traceability of prefabricated sets	
		§2.5: Addition "The holder's communication must be done with respect.... »	
		§2.5.5: Added possibility of stock holder remarking for prefabricated fittings	
		§3.3.1.3.5: Addition of table for ATG B600	
§3.3.2: Addition of prefabricated sets to the table			
10	07/21/23	§1.1 and 2.4.4.8: Addition of water supplies (ATG B600) with prefabricated fittings	Immediate: no certified products
		§1.2.2: Added the possibility of using ATG-PLT or NF136 certified fittings on prefabricated fittings	
		§2.2.3: CCH2020-05: addition of R and Rp 1/4 thread	
		§2.5: Addition: - "When the holder uses.....request for these. »	
		§2.5.1: Consumer code R115-2 replaced by R433-2	
		§2.5.3.2 and §2.5.3.3: Addition "If this is not possible.... and all of the information relating to the NF mark must be available in the documentation"	
		Part 3: Type of requests: addition of table of management terms and conditions for maintaining rights of use	
§4.1.2: Addition: " In the case of maintaining the NF mark for a product, CERTIGAZ carries out a surveillance audit every 2 years"	Immediate. No impact on certified products		
§5.2: change of Certigaz address			
11	05/27/24	§1.1, §1.2, and §2.4.4.8: Addition of the family of prefabricated rising pipe elements	Immediate: no certified products
		§2.2.3: CCH202-02: Addition of label position requirement	Deadline of 12 months from the date of publication of the rules for implementation. Disposal of stocks possible without modification.
		§2.5.3: Withdrawal of article R115-2 of the consumer code	
		§3.3.1.3.5: Modification of admission and monitoring requirements for the ATG B600	Immediate. No impact on certified products
		§ 4.1.1.1: Addition of conditions for surveillance tests in the absence of manufacturing	Immediate. New applicable provision
§ 5.4 CTIF taken over by CETIM and LRCCP becomes ELANOVA	Immediate. No impact on certified products		

(1) Date of application of the change in relation to the "date of application" of these Certification Rules. In the case of a specific transitional period for the application of a change by holders, it is defined in paragraph 2.2) "Transitional periods"

The modifications made are identified by means of a vertical bar in the margin.

Part 1

PRESENTATION AND SCOPE OF APPLICATION

1.1 Scope

This application, the NF RAC-GAZ mark (NF540), concerns:

► interchangeable fittings and mechanically assembled connection sets for gas installations. These products concern the following product families for gas installations:

- interchangeable brass screw fittings (without solder end)
- interchangeable steel screw fittings (without soldering or soldering ends)
- brass solderable fittings (at least one end is solderable)
- welded or brazed steel fittings (at least one end is to be welded or brazed)
- prefabricated fittings and brazed brass/copper tube fittings
- prefabricated brazed steel/copper tube fittings
- welded or brazed sets with stainless steel tube

► the manufactured elements of the rising pipes

► sealing materials for threaded connections (anaerobic composition or non-hardening sealing composition) for gas installations

► elastomer materials for seals for gas installations

► connection kits for a gas appliance producing hot, cold and energy at the installation

As all of these products are intended for gas installations, these products are considered to have safety obligations within the meaning of article 10 of the General Rules of the NF mark.

Definition :

Gas installation connection : screwed, brazed or welded connection. This fitting is made up of brass or steel fitting bodies and possibly nuts. This fitting complies with one or more of the following specifications: NF E 29-532, NF E 29-536, CCH2020-04 or CCH2020-05.

Prefabricated connection : brazed or welded connection (bracket, steel-copper sleeve, etc.) other than rising column and which complies with ATG B600.

Feeder: feeder used in technical rooms or gas technical cupboards complying with ATG B600. Collectors with several inlets and/or outlets are assimilated to feeders.

Prefabricated element : rising pipe compliant with ATG B600.

Connection kit : Set of components constituting gas equipment allowing the gas connection of a device to an installation to the exclusion of any other use; it is generally made up of gas pipes, fittings, seals and a tap. This kit complies with CCH2020-02.

Connection kit fitting : one of the fittings composing a connection kit.

Sealing material : sealing material for threaded connections in contact with 1st, 2nd, and 3rd family gases and hot water. This material complies with standard NF EN 751-1 or NF EN 751-2 .

Elastomeric material: elastomeric material usable for sealing components for gas installations: seal and/or membrane. This material complies with standards NF EN 549 and/or NF EN 682.

1.2 Products and product lines

1.2.1 Interchangeable fittings in brass or steel

A connection for gas installations is defined according to the applicable standards and specifications by:

- the inlet connection (type, size),
- the outlet connection (type, size),
- the size and dimensions,
- the materials,
- the manufacturing methods.

Fitting ranges

A range of fittings for gas installations is made up of a set of fittings which have the same:

- family defined in paragraph 1.1
- design of fittings with the exception of geometric differences linked to different sizes,

which differs by:

- the inlet and/or outlet connections,
- manufacturing process
- the manufacturing and/or control sites, according to the criteria defined in the table below,
- options without influence on the certified characteristics.

In addition, the ranges of fittings follow the following additional rules:

Note: in the case where fittings are sold with a non-removable mechanical link (example: meter replacement plate). The whole can be certified if each of the connections is itself certified.

In this case, the mechanical connection between the fittings is not covered by the requirements of the NF540 Certification Rules.

Connection type	Manufacturing process	Elements that may be different for a range of fittings			
		Manufacturing site	Leak testing site	Final control site (1)	Product control site (2)
Brass fittings	Turning	Yes	Not applicable	No	No
	Stamping + machining	Yes	Not applicable	No	No
	Foundry + machining	Yes	No	No	No
Steel fittings	Turning	Yes	Not applicable	No	No
	Foundry + machining	Yes	Yes	No	No
Brazed fittings	Brazing	No	No	No	No
Brazed fittings	Soldering	No	No	No	No
Connections with stainless steel tube	Miscellaneous	No	No	No	No

(1) : The “final control site” corresponds to the site which carries out the final control allowing the release of the products.

(2) The “product control site” corresponds to the site which controls the definition of the product, industrial processes, purchasing, product reception control and packaging.

An NF certificate can only cover products from a single range .

1.2.2 Prefabricated brazed and brazed fittings

A prefabricated brazed or welded connection for gas installations is defined according to the applicable standards and specifications by:

- the inlet connection (type, size),
- the outlet connection (type, size),
- the size and dimensions,
- the materials,
- the manufacturing methods.

Ranges of prefabricated fittings, feeders, prefabricated, brazed and brazed elements

A range of prefabricated or brazed or brazed fittings for gas installations is made up of a set of fittings which have the same:

- family defined in paragraph 1.1
- design of fittings with the exception of geometric differences linked to different sizes,
- brazing or welding site

which differs by:

- the inlet and/or outlet connections,
- the different input materials (different silver rates). For the same reference of a prefabricated connection and the same brazing/welding site, it is not possible to have filler materials with a different silver rate.
- manufacturing process
- options without influence on certified characteristics

The end connections of brazed and welded assemblies must be either:

- NF540 certified. With the exception of steel sleeves (example: steel sleeve used for steel/copper sleeves) which are considered as a component of the brazed-welded connection (the steel sleeve alone cannot be NF540 certified)
- ATG-PLT certified
- NF136 certified

1.2.3 Gas appliance connection kits

Due to the configuration of these sets, the certification of the ranges is organized as follows:

- range of fittings. The corresponding certificates will indicate that these fittings cannot be marketed alone and that they are only intended to be incorporated into gas appliance connection kits
- range of gas appliance connection kits. The certificate lists all the certified connection kits for a holder.

Ranges of fittings for gas appliance connection kits

A connection for connection kits is defined according to the applicable standards and specifications by:

- the inlet connection (type, size),
- the outlet connection (type, size),
- the size and size,
- the materials,
- the manufacturing methods.

In addition, the ranges of fittings for kits follow the following additional rules:

Type of fittings		Elements that may be different for a range of fittings							
		Product control site (1)	Brazing site	Forging/foundry site	Tube forming site	Leak testing site	Nut crimping site or socket deformation	Final control site (2)	Packaging site
Connection with copper tube	Connections without brazed elements	No	Not applicable	Yes	Yes	Not applicable	Yes	No	Yes
	Connections with brazed elements	No	No	Yes	Yes	No	Yes	No	Yes
Fittings without copper tube	Connections with foundry elements	No	Not applicable	Yes	Not applicable	Yes	Yes	No	Yes
	Non-foundry element connections	No	Not applicable	Yes	Not applicable	Not applicable	Yes	No	Yes

(1) The “product control site” corresponds to the site which controls the definition of the product, industrial processes, purchasing, product reception control and packaging.

(2) The “final control site” corresponds to the site which carries out the final control allowing the release of the products.

An NF certificate can only cover products from a single range of fittings

Ranges of device connection kits

A range of gas appliance connection kits consist of a set of appliance connection kits for the same holder. This range is made up for each reference of the different fittings constituting it (see fitting range).

1.2.4 Sealing materials (anaerobic composition or non -hardening sealing composition)

A sealing material for gas installations is defined according to the applicable standards and specifications by:

- its commercial designation,
- its class,

Ranges of sealing materials

An NF sealing material certificate can only cover a single definition of a product, a single commercial designation

1.2.5 Elastomeric material for seals and membranes

An elastomeric material usable for gaskets for gas installations is defined according to the applicable standards and specifications by:

- its commercial designation,
- its nominal hardness,
- its temperature class,
- its possible resistance to ozone,

Elastomer ranges for seals and membranes

An NF certificate for elastomeric material for seals can only cover a single definition of a product (elastomeric mixture), a single commercial designation

1.3 Who can apply for the NF mark and why?

These Certification Rules are accessible to any applicant whose products fall within the scope defined above and meet the technical requirements described in part 2 of this document.

Definitions of applicants/holders, agents, distributors:

a – Applicant / holder:

Legal entity which ensures control and responsibility for compliance with all the requirements defined in the Certification Rules of the NF RAC-GAZ mark.

These requirements cover at least the following stages: manufacturing, assembly, quality control, marking, packaging as well as placing on the market and specify the critical points of the different stages.

b – Agent:

Legal or natural person established in the European Economic Area (EEA) or in the European Free Trade Association (EFTA) which has a function of representing the applicant/holder outside the EEA or in the European Free Trade Association (EFTA) and has a written mandate from the latter informing him that he can act in his name and specifying in what framework (missions and associated responsibilities and financial aspects, complaints, contact person for the certifying organization, among others) in the NF mark certification process following the clauses of the Certification Rules. The agent can be the distributor or the importer, his different functions are clearly identified.

c – Distributor :

Legal entity distributing the applicant's/holder's products which does not intervene on the product to modify compliance with the requirements of the NF mark.

The types of distributors can be as follows:

- distributors who do not intervene technically on the product and who distribute the product under the trademark of the holder,
- distributors who do not intervene technically on the product and who distribute the product with a change of commercial brand (need to maintain the right of use or request for the right of use if the applicant does not wish explicit reference to be made to the applicant/holder).

Note: *the applicant's sites which guarantee compliance with certain requirements of the standard are considered subcontractors of the applicant and may be subject to control in accordance with the requirements of the standard.*

The applicant/holder undertakes in particular not to submit counterfeit products for certification.

It is the responsibility of the applicant/holder to ensure that the regulations applicable to their product are effectively respected.

1.4 The NF mark

Created in 1938, the NF mark is a collective certification mark, which aims to certify the conformity of products to the national, European and international normative documents concerning them, which can be supplemented by additional specifications, under conditions defined by certification standards. It is delivered by AFNOR Certification and its network of partner organizations which constitute the NF network.

A voluntary product certification mark, the NF mark meets the requirements of the Consumer Code, in particular by involving interested parties in the validation of certification standards, by defining rules for marking certified products and clear and transparent communication on the main certified characteristics.

The right to use the NF mark is granted, on the basis of conformity to one or more standards and generally to an entire certification framework, for a product coming from an applicant and a designated design and/or manufacturing and/or marketing process. The granting of the right of use cannot in any way substitute the responsibility of CERTIGAZ for that which legally falls to the company holding the right to use the NF mark.

The NF mark strives to control the safety characteristics of people and property, fitness for use and durability of products, as well as additional characteristics allowing it to differentiate itself on the market.

Unanimously recognized by economic players, consumers, public authorities and institutions, the NF mark has built an indisputable reputation, recognized by the very rare status of a well-known mark in France. Its notoriety is based on:

- compliance with standards, symbol of the consensus obtained between interested parties,
- the assurance of having quality, safe and efficient products, which have been subject to controls,
- the concern to meet the evolving expectations of the markets,
- confidence in the robustness of the certification processes implemented for its delivery (rigor, transparency and impartiality, control of the processes),
- confidence in the competence and impartiality of the organizations which deliver it.

The operation of the NF mark is based on a network of mandated certifying organizations, technical secretariats, laboratories, inspection organizations, auditors, regional facilitators with recognized technical expertise, who constitute with AFNOR NF Network certification.

In accordance with the General Rules of the NF mark, AFNOR Certification entrusts the exercise of the various functions necessary for the management of the NF RAC-GAZ mark to CERTIGAZ, known as the mandated organization.

CERTIGAZ is responsible to AFNOR Certification for the operations entrusted to it and which are the subject of a contract with AFNOR Certification.

Part 2

THE REQUIREMENTS OF THE REFERENCE

2.1 The certification framework

The framework for this application of the NF mark, within the meaning of the Consumer Code, is made up of:

- the General Rules of the NF mark which establish the general organization and conditions of use of the mark,
- of these Certification Rules which describe the technical characteristics to be respected as well as the methods for checking compliance with these characteristics,
- standards referenced in these Certification Rules, as well as any additional technical specifications.

These Certification Rules, which are part of the certification of products and services other than food provided for in the Consumer Code, specify the conditions for application of the General Rules of the NF mark to products defined in part 1 .

The company (applicant/holder) undertakes to respect the Certification Rules and to implement the appropriate changes communicated by CERTIGAZ.

2.2 Additional standards and specifications

2.2.1 Standards, specifications and worksheets

Fittings

NF D 36-136 (06/2019)	Dimensional characteristics of mechanical connections intended to be installed on pipes for gas installations <i>NOTE : the connections defined in standard NF D 36-136 replace the definitions of the various connections in the standards cited below.</i>
NF E 29-532 (05/2017)	Dismountable fittings with flat gaskets intended to be installed on pipes for gas installations.
NF E 29-536 (05/2017)	Dismantable fittings with sphero -conical junction intended to be installed on pipes for gas installations.
XP E 29-195 (01/2017)	Gas installation fittings intended to be positioned at the gas meter outlet
NF EN 10204 (01/2005)	Metal products: Types of control documents
CCH 2020-02 (10/2020)	Connection kits for a gas appliance producing hot, cold and energy to the installation
CCH 2020-04 (05/2020)	Dismountable fittings with flat gaskets for LPG installations
CCH 2020-05 (05/2020)	Removable fittings with sealing in the thread for gas installations
ATG B.521 (06/2005)	Fuel gas installations – Steel tubes and assemblies
ATG B.524 (06/2005)	Fuel Gas Installations – Copper Tubes and Assemblies
NF M 88-781	Liquefied hydrocarbon installations - Regulators, automatic diverters, having a maximum expansion pressure of 4 bar, with a maximum capacity of 150 kg/h, associated safety devices and adapters for butane, propane and their mixtures - Application of the European standard EN 16129 Use of the “cap” shape in Figure 2 of the standard
ATG B600 (03/2021)	Prefabricated elements

Sealing materials for threaded connections

NF EN 751-1 (11/1997)	Sealing materials for threaded connections in contact with 1st · 2 nd and 3 rd gas families and hot water
NF EN 751-2 (11/1997)	Sealing materials for threaded connections in contact with 1st · 2 nd and 3 rd gas families and hot water

Elastomeric materials for seals

NF EN 549 (03/1995)	Rubber-based materials for seals and membranes for gas appliances and gas equipment
NF EN 549 (07/2019)	Rubber-based materials for seals and membranes for gas appliances and gas equipment
NF EN 682 (05/2003)	Specification of materials for gaskets for pipeline joints and fittings conveying gas and hydrocarbon fluids
NF EN 682/A1 (12/2005)	Specification of materials for gaskets for pipeline joints and fittings conveying gas and hydrocarbon fluids

The standards and documentation booklets (NF, XP, FD) are available from the Sales Department of:
AFNOR – 11 rue Francis de Pressensé – F 93571 LA PLAINE ST-DENIS Cedex
tel: +33 (0)1 41 62 80 00 – www.afnor.org

The SRAC specifications are available on request from CERTIGAZ and can be downloaded from the website www.certigaz.fr.

The CCH specifications can be downloaded from the website www.afgaz.fr.

The CNPG guides are available on the website www.cnpq.fr.

2.2.2 Specifications and applicable rules

SRAC100-NF	Specific connections for gas installations and gas distributors
SRAC326-NF	Renovation kit for GAZPAR meter outlet bracket – S2300 or S2400 box
SLAB100	Specifications for manufacturer laboratory authorization.

The applicable versions of these specifications, managed by CERTIGAZ, are available on the website www.certigaz.fr

2.2.3 Specific technical requirements**Materials for interchangeable fittings**

The materials used for the manufacture of brass and steel fittings comply with the tables in appendices A of standards NF E 29-532 and NF E 29-536.

In addition to the materials listed in appendices A, grades CC753S, CC754S and CC757S can also be used for foundry fittings.

Foundry fittings:

For all brass fittings from a foundry process, any impregnation process is prohibited to make the fittings watertight.

The fittings from the foundry are checked for 100% tightness. This check is carried out on the fitting after all the machining phases.

CCH2020-05:

Addition to table 2 of CCH2020-05 of values for R-Rp3/8

DN	10	12
Thread	R or Rp 1/4	R or Rp 3/8
Nominal torque to apply (Nm)	15	20

NF EN 751:

In addition to the normative requirements, these provisions apply:

- Tightening torques to apply for the preparation of the test pieces: R1/4: 15 Nm; R1/2: 25 Nm; R1"1/2: 80 Nm
- Foaming accounting product: possibility of using a product compliant with the NF EN 14291 standard (foaming solution for leak detection on gas installations)
- Sealing (Efficiency): the leak rate must be less than 20 cm³ / h

CCH2020-02:

The applicable tightening torques of the nuts in Table 8 of CCH2020-02 must be indicated in the installation instructions. The tightening torque can also be indicated on the nut.

Marking of connections by labels:

In the case of marking of fittings intended to be brazed with labels, the holder must control the location of the label so that it is positioned as far as possible from the brazing area.

ATG B600:

In paragraph 10.1.3:

“Fittings intended for use at a pressure less than 500 mbar” is replaced by “Fittings intended for use at a pressure less than or equal to 500 mbar”

“Fittings intended for use at a pressure greater than or equal to 500 mbar” is replaced by “Fittings intended for use at a pressure greater than 500 mbar”

NF D 36-136:

For the G3/4 LPG line connection (§4.3.8 of the standard), figure 22 is replaced by the following figure:

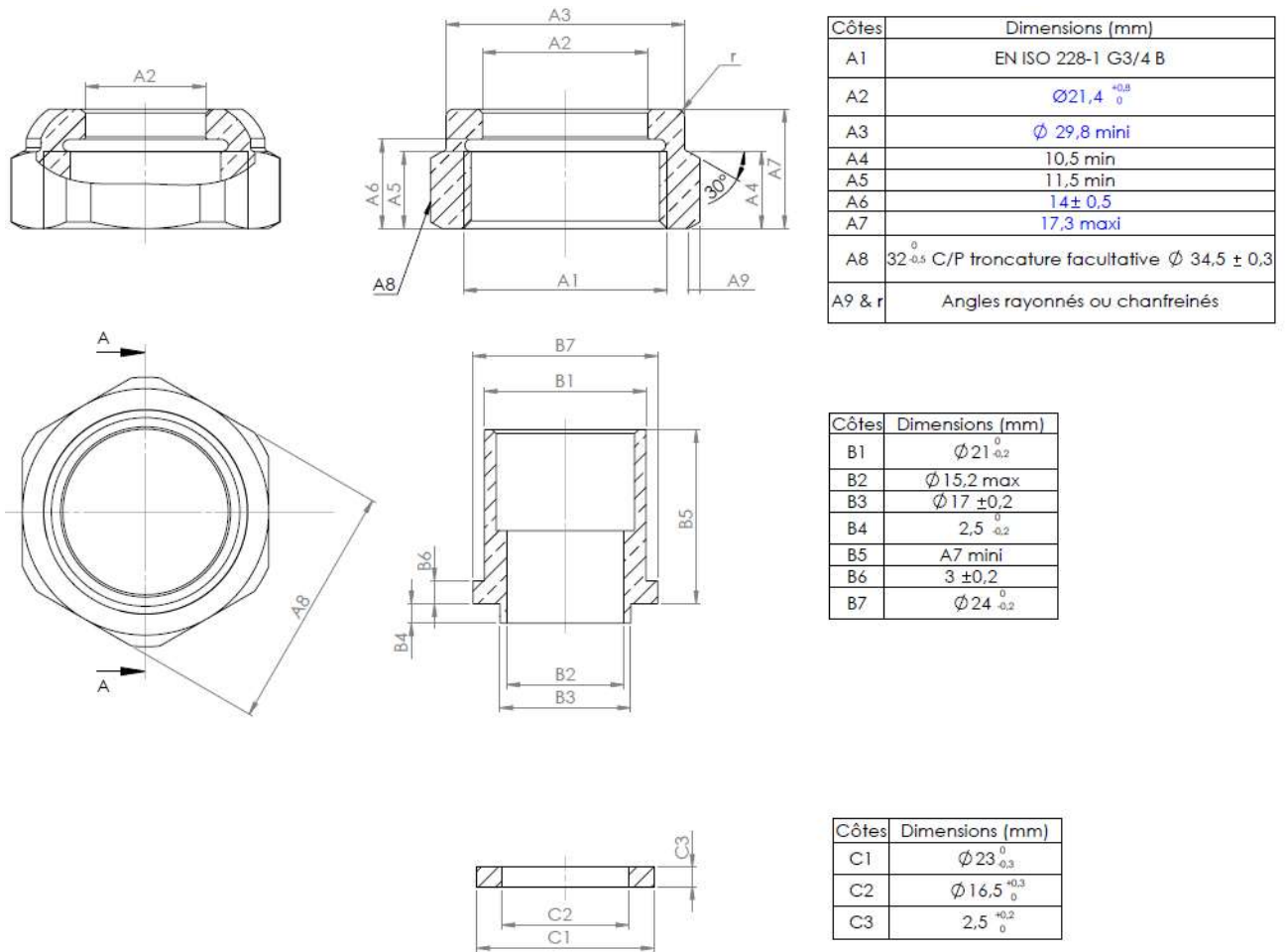

Figure 22 - douille, érou, joint

2.3 Regulations

The products covered by this certification framework must comply with the applicable French regulations concerning them and in particular:

- Environmental Code (Book V – Title V – Chapter VII “Products and equipment at risk)
- Decree dated February 23rd, 2018 relating to the technical and safety rules applicable to combustible gas installations in individual or collective residential buildings, including common areas
- CNPG Guide (National Center of Expertise for Gas Energy Professionals) “Gas appliances and equipment”. The current version is available on the CNPG website

The applicant/holder undertakes to respect them for products relating to the NF RAC-GAZ mark and must be able to prove this.

2.4 Quality management provisions

2.4.1 General

The minimum provisions in terms of quality assurance, which the applicant/holder must adopt and put in place so that products which benefit from the NF RAC-GAZ mark are manufactured and/or distributed permanently in compliance with this standard are specified below.

By using the NF mark, the holder makes a commitment to the permanent quality of the certified products that it manufactures and/or delivers to its customers. As part of the NF mark, the applicant/holder provides proof of the existence and effectiveness of their quality file.

The objective to be achieved by the applicant/holder is to control the processes (within the meaning of the NF EN ISO 9000 standard) and to maintain the conformity of its products to the initially accepted models.

Achieving this objective requires the applicant/holder to implement their own means, the performance of which is assessed during the admission visit and verified during follow-up visits. The quality requirements of this NF mark are defined below and are based on the requirements of the NF EN ISO 9001 standard, the scope of which is limited to the field of application. The tables below summarize these requirements according to the version of the ISO 9001 standard.

Quality Requirements	ISO 9001 - 2015	Requirements *
Quality management system		
General requirements	4.1 - 4.2	Required for processes related to product manufacturing.
Documentation requirements	4.4 – 7.5	Required
Management Responsibility		
Management commitment	5.1 - 5.2	Required
Responsibility and authority	5.3	Required
Management review	9.3	Required
Resource management	7.1 to 7.4	Required
Production of the product		
Planning for product realization	8.1	Required
Customer processes	8.2	Required for customer complaints management
Purchases	8.4	Required
Mastery of production and service preparation	8.5.1	Required
Identification and traceability	8.5.2	Required
Product preservation	8.5.4 - 8.5.5	Required
Mastery of monitoring and measuring devices	7.1.5	Required
Measurement, analysis and improvement		
Product monitoring and measurement	8.6 - 9.1	Required
Control of non-compliant product	8.7 - 10.2	Required
Corrective action	10.2	Required

(*) These requirements also apply to any subcontractors

2.4.2 Minimum requirements for quality organization

The applicant's/holder's commitments regarding product quality must be written and signed by management, adapted, known and implemented at all levels. The applicant/holder must establish a functional organization chart and establish job descriptions for all people who participate in the production of certified products.

The applicant must formalize in writing in a quality file or quality manual, the arrangements in terms of organization, documents, material and human resources that it puts in place to guarantee control of product quality.

The applicant/holder must describe and have an organization in place to record, process and settle customer complaints relating to certified products. Records relating to these actions must be kept for a relevant period, defined by the applicant/holder.

2.4.3 Quality system certification

A manufacturer whose quality system has been certified by a recognized certification organization is expected to meet the applicable quality management requirements. The certificates recognized by CERTIGAZ are those issued by quality system certification organizations accredited by an accreditation organization that is a member of the EA.

The applicable quality management requirements and the production of the product(s) concerned must be covered by the standard and the scope of the quality system certification.

In this case the assessment by CERTIGAZ is limited:

- in the “Resource management”, “Product production” and “Measurement, analysis and improvement” paragraphs of the ISO 9001 standard,
- and the examination of manufacturing controls as defined in paragraph 2.4.4.

It can nevertheless be extended to any applicable quality system requirement not covered by the framework and/or the scope of quality system certification or whose effectiveness may be called into question.

2.4.4 Product specific requirements

2.4.4.1 General

As part of the quality system, products are examined and appropriate tests, defined in the applicable standard(s), or equivalent tests are carried out to verify their conformity.

To this end, the manufacturer implements a manufacturing control plan at least equivalent to the “Standard Control Plan” in paragraph 2.4.4.8.

2.4.4.2 Controls during manufacturing

The manufacturer may carry out all or part of the controls mentioned in the “Standard Control Plans” (in paragraph 2.4.4.8) during manufacturing as long as he can ensure that compliance with the requirements concerned will be maintained until the stage of the delivered product.

2.4.4.3 Control of raw materials and components

The manufacturer must verify with its possible supplier(s) the conformity of the products delivered to the applicable specifications of the reference standard(s), either by ensuring that the supplier’s quality management system allows it to obtain a degree of sufficient confidence in the quality of the products purchased, or by carrying out the appropriate checks itself by taking samples from the batches received.

The holder must have in his possession certificates of material conformity according to standard NF EN 10204 to attest to the material conformity of the products supplied according to the following requirements:

Certificates allowing to demonstrate the conformity of component materials are available from the applicant/holder.

Matter	Manufacturing process	Certificate type (minimum)	
		Material composition	Mechanical characteristics
Brass	Turning	3.1	2.2
	Stamping	3.1	N / A
	Foundry	3.1	N / A
Steel	Turning	3.1	3.1
	Foundry	3.1	N / A
Copper	Forming, brazing or brazing	3.1	3.1
Stainless steel	Miscellaneous	3.1	3.1

2.4.4.4 Unit controls

The controls identified 100% in the “Standard Control Plans” must be carried out on each product manufactured at a stage of manufacturing to ensure that compliance with the requirements concerned will be maintained until the stage of the delivered product.

2.4.4.5 Controls by sampling or statistics

These controls are identified in the “Standard Control Plans”.

Unless otherwise indicated in the “Standard Control Plans”, the sampling plan is left to the initiative of the manufacturer. This plan must define the sampling method (lot size, conditions and number of samples), the conditions of acceptance or refusal. The sampling plan must be defined to ensure the conformity of all individuals in a batch, it must be adapted to the manufacturing processes implemented.

2.4.4.6 Control records

Records relating to the results of controls must be accessible to inspectors/auditors.

2.4.4.7 Control methods

The choice of methods for controlling raw materials and during manufacturing is left to the applicant/holder provided that the methods used make it possible to obtain significant results under the conditions defined in article 2.4.4.8.

The inspection methods must comply with the requirements of the standards. However, methods and equipment different from those described in these standards may be used provided that the results are equivalent.

2.4.4.8 Minimum requirements for inspections and tests during acceptance and manufacturing

Upon receipt then during production, the applicant/holder is required to carry out the following checks and tests at the minimum frequency indicated in the “Standard Control Plans” specific to each product family.

The samples are distributed so as to be representative of the production in the determined period.

A batch is a set of products, of the same model, manufactured during the same manufacturing campaign. For nuts, a batch cannot be made up of several batches of raw material.

By manufacturing campaign we mean the period during which a defined and homogeneous quantity of products is manufactured under uniform conditions. The batch is defined and marked by the manufacturer.

Depending on the manufacturing method of the interchangeable brass or steel fittings, the arrangements made for the manufacturing and control of the products are as follows:

Standard control plan: Interchangeable fittings															
Type of product	Manufacturing process							Process control							
	Turning	Stamping	Foundry	Machining	Nut crimping or socket deformation			Manufactured together with stainless steel tube	Waterproofing	Material (1)	Components (1)	Dimensional, overall dimensions (1)	Marking (1)	Nut tightening resistance (2)	Resistance to cracking in ammoniacal medium (2)
Screw connections	X				X				N/A	S	S	S	S	S	S
		X		X	X				N/A	S	S	S	S	S	S
			X	X	X				100%	S	S	S	S	S	S
Solder fittings	X				X				N/A	S	S	S	S	S	S
		X		X	X				N/A	S	S	S	S	S	S
			X	X	X				100%	S	S	S	S	S	S
Braze or solder fittings	X				X				N/A	S	S	S	S	S	S
Set with stainless steel tube								X	100%	S	S	S	S	S	S

100% = unit control S = Statistical control NA = Not Applicable

(1) = Statistical control to be carried out on each batch manufactured (sampling plan defined by the manufacturer)

(2) = Statistical control to be carried out at a minimum:

- on each batch of crimping nut or deforming socket (for captive nut) supplied or manufactured (a batch of nut or deforming socket cannot be composed of several batches of raw material)
- at least twice a year on complete fittings from the same range of certified fittings.

Standard control plan: Prefabricated connections, feeders and prefabricated elements (ATG B 600)		
Control	On production line	Offline
Raw materials (chemical composition, physical characteristics)		S (1)
Components		S (1)
Dimensional / footprint		S (1)
solder or solder	100%	
Waterproofing	100%	
Marking		S (1)
Conditioning		S (1)
Brazing and brazing : personnel qualification, DMOS, QMOS		S (2)

100% = unit control S = Statistical control

- (1) = Statistical control to be carried out on each batch manufactured (sampling plan defined by the manufacturer)
- (2) = Qualification management by the manufacturer

Standard control plan: Connections for gas appliance connection kits (CCH 2020-02)		
Control	On production line	Offline
Raw materials (chemical composition, physical characteristics)		S (1)
Components		S (1)
Dimensional / footprint		S (1)
Waterproofing	100% if: -connections with brazed elements -fittings from foundry	
Marking		S (1)
Packaging / instructions		S (1)
Nut tightening resistance		S (2) (4)
Resistance to cracking under stress in ammoniacal environment		S (2)

100% = unit control S = Statistical control

- (1) = Statistical control to be carried out on each batch manufactured (sampling plan defined by the manufacturer)
- (2) = Statistical control to be carried out at a minimum:
 - on each batch of crimp nut or deforming socket (for captive nut) supplied or manufactured (a nut batch cannot be composed of several batches of raw material)
 - at least twice a year on complete kits from the same range of certified kits
- (3) = Statistical control to be carried out at least once a year.
- (4) := At least once a year for each type of nut

Standard control plan: Sealing materials for threaded connections (NF EN 751-1)		
Control	On production line	Offline
Raw materials (chemical composition, physical characteristics)		S
Appearance, color, homogeneity	S	
Density, viscosity	S	
Reactivity test	S	
Mechanical resistance to loosening		S
Waterproofing		S
Pressure resistance		S

S = Statistical control

Standard control plan: Sealing materials for threaded connections (NF EN 751-2)		
Control	On production line	Offline
Raw materials (chemical composition, physical characteristics)		S
Appearance, color, homogeneity	S	
Density, viscosity	S	
Waterproofing		S
Pressure resistance		S

S = Statistical control

Standard control plan: Elastomeric material		
Control	On production line	Offline
Raw materials (chemical composition, physical characteristics)		S
Rheometry	On every charge	
Hardness	S	
Rupture elongation		S

S = Statistical control

2.4.4.9 Minimum traceability requirements

Traceability of batches of materials and controls in relation to x batches of finished products must be ensured internally by the holder.

Connections:

The holder must be able to demonstrate upward and downward traceability and the connection is identified by a batch number. He must be able to identify the manufacturing process and the different stakeholders based on the batch number.

Gas appliance connection kits:

The holder must be able to demonstrate upward and downward traceability and the assembly is identified by a batch number. He must be able to identify the batch(es) of fittings used.

Prefabricated brazed and brazed fittings:

The holder must be able to demonstrate upward and downward traceability and the assembly is identified by a batch number. He must be able to identify:

- the batch(es) of fittings used
- the brazing or welding site

The management of the qualification of brazers must make it possible to identify qualified brazers over a manufacturing period

2.4.5 Register control

The registers in which the results of the control tests are recorded can be requested by CERTIGAZ and examined during the audits by the auditors who also evaluate the control means.

2.4.6 Customer complaints

The applicant/holder will register and process all customer complaints relating to NF certified products.

2.5 Marking

Marking is an integral part of product certification.

Beyond the identification of a certified product and its traceability, the marking of a product with the NF logo ensures better protection of users and allows the defense of holders against abusive use and counterfeiting.

The holder's communication must be done in compliance with the principles of clarity and sincerity. The holder must take particular care to indicate the product(s) subject to NF certification and respect all indications in the applicable graphic charter of the NF mark available from CERTIGAZ, under penalty of sanctions, in compliance with the General Rules of the NF mark.

The reproduction and affixing of the AFNOR, AFNOR Certification and CERTIGAZ logos are strictly prohibited without the prior agreement of these organizations.

The reproduction and affixing of the COFRAC logo as well as the reference to CERTIGAZ accreditation by the applicant/holder (and its customers) are prohibited by CERTIGAZ. CERTIGAZ only authorizes the full reproduction of the certificates it has issued.

When the holder uses the NF mark, he undertakes to:

- not use the certification of its products in a way that could harm the certification organization, nor make any statement about the certification of its products that the certification organization may consider misleading or unauthorized, in particular:
 - not use the NF mark in an abusive manner or in a manner that does not comply with the certification framework and the applicable graphic charter;
 - not use the AFNOR, AFNOR Certification and CERTIGAZ logo.
- remove from its website any link to sites of the AFNOR Group and/or that of the certification organization, if requested by the latter. »

2.5.1 Reference texts

The Consumer Code

Article R 433-2 of the Consumer Code stipulates that:

“When reference is made to certification in advertising, labeling or presentation of any product or service as well as in commercial documents of any nature relating to it, the following information must be included in the knowledge of the consumer or user:

- the name or company name of the certifying organization or the collective certification mark,
- the name of the certification framework used,
- the terms and conditions under which the certification reference system can be consulted or obtained. »

The purpose of mentioning the main certified characteristics is to make transparent, for consumers and users, the technical characteristics covered by the NF mark. It thus promotes the certification and its content. “Certified characteristic” is any technical characteristic whose content is controlled within the framework of the NF mark.

The General Rules of the NF mark

The marking rules below are intended to guide the holder in complying with regulatory requirements and the requirements of NF certification. The General Rules of the NF mark specify the conditions of use, the conditions of validity, and the terms of sanction during abusive use of the NF mark.

Without prejudice to the sanctions provided for in the General Rules of the NF mark, any erroneous announcement of certified characteristics, and any fraudulent use of the NF logo, exposes the holder to prosecution for fraud and/or false advertising.

2.5.2 The NF logo

The NF logo must ensure the identification of any certified product.

The holder undertakes to respect the graphic charter of the NF mark. The NF logo and its graphic charter are available from CERTIGAZ .

The NF certified product is subject to a designation and identification distinct from those of non-NF certified products.

The holder must only use the NF logo to distinguish NF certified products and this without there being any risk of confusion with other products and in particular non-NF certified products.

It is recommended that the holder first submit to CERTIGAZ all documents where the NF mark is mentioned.

2.5.3 NF marking methods

This part describes both the procedures for affixing the NF logo and the marking of essential certified characteristics.

The marking must, whenever technically possible, be carried out as follows:



This part covers the following aspects:

1. marking of the NF logo on the NF certified product
2. marking of the NF logo on the packaging of the NF certified product
3. marking of the NF logo on documentation and on websites

As indicated in paragraph 2.5.1, it is recommended to inform the consumer about the main reasons and advantages of using a certified product. In the NF certification system, the certified essential characteristics must appear on at least one of the supports (product, packaging or documentation).

The lists of certified products distributed by CERTIGAZ and the certificates issued to the holder mention or guarantee the following certified characteristics:

- | |
|---|
| <ul style="list-style-type: none"> ▪ Reference standard(s) ▪ DN ▪ MOP ▪ Dimensional characteristics ▪ Waterproofing ▪ Benchmark flow (if applicable) ▪ Mechanical resistance ▪ Marking, instructions, packaging |
|---|

The holder has the choice of reproducing the above information himself in his documentation or referring to the certificates or lists distributed by CERTIGAZ. For the French market, this information must be given in French.

The certified characteristics can be indicated to the consumer according to the marking methods in the following example:



- | |
|--|
| <ul style="list-style-type: none"> - certified characteristic 1 - certified feature 2 - certified feature 3 |
|--|

2.5.3.1 Marking of the NF RAC-GAZ certified product

Any product benefiting from the right to use the NF RAC-GAZ mark must clearly bear:

- ▶ the indications mentioned in the “MARKING” chapter of the specification(s) concerned
- ▶ manufacturer identification
- ▶ the NF logo defined in paragraph 2.5.2

In the event of technical impossibility, the words “RAC-GAZ” and “CERTIFIED BY CERTIGAZ” may not be present. If present, these markings must be legible.

The minimum admissible marking is as follows:



Note:

However, due to the specificity of NF RAC-GAZ certified products, it is authorized to deviate from the requirements defined below as follows:

- ▶ the minimum size requirement for the logo defined in the graphic charter is replaced by a notion of readability.
- ▶ if it is impossible to mark the NF logo in the absence of a sufficient surface:
 - if the flat surface does not allow obtaining an NF logo with a minimum height of 5mm
 - if the logo marking can only be carried out on a cylindrical part whose diameter is less than or equal to 12mm the NF logo can be replaced by the letters “NF”

In addition, depending on the processes for marking the NF logo on the product (example: micro-percussion, laser, stamping, foundry, injection, wheel, stamping, etc.), it is authorized to carry out the marking in wire form:



2.5.3.2 Marking on the packaging of the NF certified product or on the product accompanying document

Affixing the logo on the packaging and instructions of certified products constitutes one of the means of promoting NF certified products. It is therefore strongly recommended that holders of the NF mark also affix the NF logo on the packaging of NF RAC-GAZ certified products.

In addition to the NF logo defined in paragraph 2.5.2, and at a minimum, the reference of the certified product as well as its commercial brand must appear on the packaging.

In addition, the requirements of the applicable standards relating to packaging markings must be respected.

Since it is not possible to affix the NF logo on flat sealing gaskets, the packaging of NF RAC-GAZ certified gaskets must include the logo in accordance with the model presented above.

The packaging of NF RAC-GAZ approved accessories may refer to this approval but they must not bear the NF logo.

The certified characteristics specified in paragraph 2.5.2 may also appear on the packaging.

In the event of technical impossibility, the mention "CERTIFIED BY CERTIGAZ" may not be present. If present, this marking must be perfectly legible and all information relating to the NF mark must be available in the documentation.

The minimum admissible marking is as follows:



2.5.3.3 Marking on documentation (technical and commercial documents, labels, posters, advertisements, websites, etc.)

References to the NF Mark in the documentation must be made in such a way that there is no risk of confusion between certified products and others.

The reproduction of the NF mark on documentation and in advertising must be carried out in compliance with the terms defined in paragraph 2.5.2.

The documentation relating specifically to approved accessories may refer to the NF RAC-GAZ approval but the NF logo must not be worn.

Reproduction of the NF mark, as defined in 2.5.2, on the letterhead of papers used for the holder's correspondence is prohibited unless the holder benefits from the NF mark for all of its products.

The certified characteristics specified in paragraph 2.5.2 may also appear on the documentation.

In the event of technical impossibility, and in particular in catalogs, the mention "CERTIFIED BY CERTIGAZ" may not be present. If present, this marking must be perfectly legible and all information relating to the NF mark must be available in the documentation.

The minimum admissible marking is as follows:



The distributor, not being the holder of the NF mark, cannot refer to it directly.

Communication on the products that it may market can only be done under the responsibility of the holder.

For a correct interpretation of this chapter, it is recommended that the holder first submit to CERTIGAZ all documents where the NF mark is mentioned.

2.5.4 Marking of gas appliance connection kits

The NF marking of the kits can be carried out as follows:

- ▶ kit sold without fixing plate: each fitting composing the kit must be identified with the NF logo. The logo with the “RAC-GAZ” application must be included on the packaging or instructions. It must be indicated “Only the elements of the gas line are NF RAC-GAZ certified”
- ▶ kit marketed with a fixing plate (pre-assembly of the fittings): the NF logo must be present on at least one of the fittings.
It is also authorized to put the NF logo on the plate but the “RAC-GAZ” application must accompany the logo in compliance with the logo in § 2.5.3.2
It must be indicated “Only the elements of the gas line are NF RAC-GAZ certified” on the instructions.

The marking of the NF logo can be carried out by label provided that it meets the marking resistance requirements of CCH2020-02.

2.5.5 Marking of products in stock during certification

For gas appliance connection kits and prefabricated fittings, the holder is allowed to mark NF products in stock under the following conditions:

- ▶ The kit is strictly identical to the certified one (definition, material)
- ▶ The manufacturer and the manufacturing process are strictly identical to those corresponding to the product certification
- ▶ The holder must make a written request in compliance with standard letter 006 of these certification rules (see part 7) and send it to CERTIGAZ;
- ▶ With its written request, the supplier must provide the list of products in stock concerned. This list must indicate:
 - The designation of the fittings / kits
 - Quantities in stock
 - Batch numbers,
 - Production dates
 - Identification of sites and manufacturing processes (same as sheet 004)
 - The date creation/updating of the list
- ▶ The holder must define the technical arrangements for marking the NF logo;
- ▶ Based on these elements, CERTIGAZ decides on the possibility of marking products in stock and informs the holder.

Part 3

GETTING CERTIFIED

The purpose of this part is to provide the applicant for the right to use the NF RAC-GAZ mark with all the information necessary to prepare their file.

Type of requests

A right to use request can be:

- ☞ A first application for admission
- ☞ An application for admission
- ☞ An extension request for product modification, or for a new product deriving from a product already admitted to the NF RAC-GAZ mark
- ☞ A request for maintenance

A **first request for admission** comes from a manufacturer who has never obtained the right to use the NF RAC-GAZ mark (first application for admission). It corresponds to a product coming from a specific manufacturing unit, defined by a commercial brand, a commercial reference specific to the product presented and technical characteristics .

A **request for admission** comes from a manufacturer who has already obtained the right to use the NF RAC-GAZ mark for other products and who wishes to obtain the right to use the NF RAC-GAZ mark for a new product or a new manufacturing site. It corresponds to a product coming from a specific manufacturing unit, defined by a commercial brand, a commercial reference specific to the product presented and technical characteristics.

An **extension request** comes from a holder and concerns a product already admitted to the NF RAC-GAZ mark and subject to modifications or a new product derived from a product already admitted to the NF RAC-GAZ mark.

A **maintenance request** comes from a holder, or a distributor, and concerns an NF certified product intended to be marketed under another commercial brand and/or having a specific reference to the product without modification of the certified characteristics.

Marketing under a commercial brand other than that corresponding to the certificate, the packaging or repackaging of the products by the distributor, must be maintained with the NF mark.



In the event of maintenance, the manufacturer and the subcontractor are each responsible for the right to use the NF mark relating to the product in question and undertake to apply the measures resulting from the sanctions taken in accordance with the Standard.

Any certified product must not be modified, even if the NF mark is maintained.

A manufacturer subject to a suspension of the right to use cannot therefore subcontract products to another holder as part of this maintenance procedure.

Likewise, the subcontractor must inform his principal of sanctions calling into question his right to use.

The table below defines the methods for managing mark maintenance for a product, depending on the different distribution methods for certified products.

Terms of management for maintaining the right to use the NF mark – Responsibility of holders and distributors							
CASE	Holder: T 		Distributor: D 	Certification management methods			Identification of the manufacturer on the packaging or instructions (3)
	Marking product (1)	Packaging trademark (1)		Maintaining the NF/ATG mark?	Management methods	Commercial brand on NF mark list and packaging	
	T marking	Packaging by T Trademark T	No modification of the packaging by D	N / A	- Management of a basic certification by the T holder : no maintenance	YES	Holder T
#1	T marking	Packaging by T Trademark D	No modification of the packaging by D	NO (2)	- Indication on the packaging of one of the following two pieces of information: - “Product T – Commercial reference XXXX or registered trademark” (the reference or trademark is that of the holder T) - “Product T – CERTIGAZ certificate/file base number” - Management of instructions and packaging by the holder T - Examination of the management of notices during the admission or surveillance audit of the T holder by CERTIGAZ	NO	Holder T
#2				YES (2)	- Maintenance request by holder T or distributor D - Management of instructions and packaging by the holder T - Examination of the management of notices during the admission audit, then monitoring of the T holder by CERTIGAZ	YES	Holder T
#3				YES (2)	- Maintenance request by holder T or distributor D - Management of instructions and packaging by the holder T - Examination of the management of notices during the admission audit, then monitoring of the T holder by CERTIGAZ	YES	Distributor D
#4	T marking	Packaging by T Trademark T	Modification of conditioning by D Trademark D	YES	- Maintenance request by distributor D - Management of instructions and packaging by distributor D - Examination of the management of notices during the admission audit, then monitoring of distributor D by CERTIGAZ	YES	Distributor D
#5	T marking	No conditioning by T	Packaging by D Trademark D	YES		YES	Distributor D
#6	D marking	Packaging by T Trademark D	No modification of the packaging by D	YES		YES	Distributor D
#7	D marking	No conditioning by T	Packaging by D Trademark D	YES		YES	Distributor D

The terms Holder and Distributor are defined in the NF certification rules

(1) : for the same holder the marking and the commercial brand may be different;

(2) : to comply with the requirements relating to the regulations (marking, manufacturer identification, etc.), the holder and the distributor organize themselves to choose between cases no. 1 and no. 2;

(3) : compliance with paragraph R557-2-5 of the Environmental Code. The notion of manufacturer and distributor is clarified in article L557-3 of the same code.

3.1 Submission of a certification application file

Before making his request, the applicant must ensure that he meets, at the time of the request, the conditions defined in these Certification Rules and in particular part 2, concerning his product and the sites concerned. It is the responsibility of the applicant/holder to ensure that the regulations applicable to their product are effectively respected.

By making a request, the applicant or holder undertakes to reserve the commercial name of its manufacture presented for admission to certified products only and to facilitate auditors with the operations incumbent on them under this Standard.

He must undertake to respect the same conditions throughout the duration of use of the NF mark.

Failing to comply with these Rules, the applicant/holder is exposed to the interruption or suspension of the investigation of his file. In particular, it is under no circumstances possible to refer to the NF mark, before obtaining the right to use the NF mark, or to present counterfeit products for certification.

The application must be presented in accordance with the conditions and models given in part 7.

The request for the right to use the NF mark must be drawn up for the attention of CERTIGAZ according to the models defined in part 7.

It must be accompanied:

- of the general information sheet concerning the applicant
- of the product sheet
- of the technical file.

In the event that the applicant is located outside the European Economic Area or outside the European Free Trade Association (EFTA), the applicant appoints an European representative who co-signs the application as well as the mandate (see part 7).

Upon receipt of the request, the following process is initiated:

- the examination of the request / the admissibility of the file,
- the implementation of controls and verifications,
- evaluation and decision

3.2 Instruction of the request / Admissibility

When processing the request, CERTIGAZ verifies that:

- the request is admissible;
- all the documents requested in the application file are present;
- the elements contained in the technical file comply with the requirements of the Certification Rules.

The request is only admissible if:

- the products subject to the request are covered by the normative documents cited in these Rules;
- the letter requesting the right to use the NF mark has been sent to CERTIGAZ (type letter 001, 002A or 002B).

As soon as the request is qualified as admissible, CERTIGAZ examines the request and:

- verifies the presence and conformity of the requested documents (see part 7);
- if necessary, requests missing elements, additional information or corrections to elements of the application file (plans, letter or application document, etc.);
- informs the applicant of the organizational arrangements (audit, audit duration, audited sites, tests to be carried out, laboratories, sampled products, etc.) and organizes the controls.

When processing the request, CERTIGAZ ensures that:

- the applicant controls and assumes responsibility for the following stages: manufacturing, assembly, quality control, marking, packaging as well as placing on the market;
- the controls and tests concerning the products covered by the request, provided for in the technical documents of these Certification Rules, are put in place.

3.3 Control methods

The controls carried out within the framework of the NF mark are of several types:

- ▶ product testing,
- ▶ audits.

3.3.1 Tests

The examinations and tests are carried out in compliance with the additional standards and specifications set out in part 2 and in compliance with the tables in paragraph 3.3.1.3.

In the case of a modification of an already certified product, a simplified test plan is possible. The applicant can then make a proposal for a testing plan when submitting their application.

The test plan is determined by CERTIGAZ on the basis of its expertise and with the help if necessary of the independent laboratory and in agreement with the applicant.

The tests are carried out either:

- ▶ by one of the independent laboratories designated in part 5 of these Rules, at the applicant's choice. In this case, the independent laboratory transmits its test report(s) to CERTIGAZ and the applicant/holder.
- ▶ in the manufacturer's laboratory authorized NF by CERTIGAZ.

The tests are carried out on samples taken by the applicant or by CERTIGAZ on a representative production and current series called a batch.

3.3.1.1 Tests carried out by an NF authorized laboratory

The NF authorized laboratory can carry out all or part of the tests.

When the manufacturer's NF authorized laboratory does not have the necessary means, it has the corresponding tests carried out by an independent laboratory of its choice.

Authorization from the manufacturer's NF laboratory follows the SLAB100 procedure "Specifications for manufacturer laboratory authorization" (available on the website www.certigaz.fr).

The NF authorized laboratory transmits its test report(s), according to its choice, to CERTIGAZ or to an independent laboratory.

This independent laboratory or CERTIGAZ examines the type test results of the authorized laboratory.

Verification tests are then carried out in the facilities of the independent laboratory or in those of the NF authorized laboratory depending on availability and choice of the applicant.

These verification tests are chosen with the agreement of CERTIGAZ following the guidelines in the tables in paragraph 3.3.1.3 below, the results of the type tests and the criticality of the tests.

The tests carried out in the manufacturer's NF authorized laboratory are carried out under the supervision of a representative of the independent laboratory or of CERTIGAZ.

Any verification test carried out in the manufacturer's NF authorized laboratory, without the permanent presence of the representative of the independent laboratory or of CERTIGAZ, must be the subject of continuous recording (case of certain endurance tests). Otherwise, the tests will be carried out by an independent laboratory.

The independent laboratory transmits to CERTIGAZ and the applicant/holder its test report(s) and its opinion on the manufacturer's test report if necessary.

3.3.1.2 Tests carried out by an accredited manufacturer's laboratory

The manufacturer's accredited laboratory can carry out all or part of the tests.

As part of monitoring the accreditation of your laboratory, the SLAB100 procedure (available on the website www.certigaz.fr) must be applied.

The manufacturer's accredited laboratory sends its test report(s) to CERTIGAZ.

CERTIGAZ examines the type test results of the manufacturer's accredited laboratory, then if it deems it necessary, has the tests carried out by an independent laboratory, in its facilities or in the facilities of the manufacturer's accredited laboratory depending on availability and choice of the applicant. cross-checking tests chosen with agreement from CERTIGAZ.

The independent laboratory sends its cross-checking test report(s) to CERTIGAZ and the applicant/holder.

3.3.1.3 Determination of tests

3.3.1.3.1 - NF E 29-532

§	Requirements	Admissions tests	Trade control
3-4-5-9	Dimensional	(1)	(6)
6	Pressure resistance and tightness test	(2)	(2)
7	Nut tightening resistance test	(3)	(4) (5)
8	Stress cracking resistance test in ammonia environment of copper alloy connecting parts	(3)	(2) (4)
10	Marking	(6)	(6)
11	Material (material analysis)	(2) (8)	(2) (8)

3.3.1.3.2 - NF E 29-536

§	Requirements	Admissions tests	Trade control
3-8	Dimensional	(1)	(6)
5	Pressure resistance and tightness test	(2)	(2)
6	Nut tightening resistance test	(3)	(4) (5)
7	Stress cracking resistance test in ammonia environment of copper alloy connecting parts	(3)	(2) (4)
9	Marking	(6)	(6)
10	Material (material analysis)	(2) (8)	(2) (8)

3.3.1.3.3 - CCH 2020-04

§	Requirements	Admissions tests	Trade control
3 and 5	Dimensional	(1)	(6)
4.2	Leak test	(2)	(2)
4.3	Nut tightening resistance test	(3)	(4) (5)
4.4	Stress cracking resistance test in ammonia environment of copper alloy connecting parts	(3)	(2) (4)
6	Marking	(6)	(6)
7	Packaging and/or instructions	(6)	(6)
8	Material (material analysis)	(2) (8)	(2) (8)

3.3.1.3.4 - CCH 2020-05

§	Requirements	Admissions tests	Trade control
3 and 5	Dimensional	(1)	(6)
4.2	Leak test	(2)	(2)
4.3	Stress cracking resistance test in ammonia environment of copper alloy connecting parts	(2)	(2)
6	Marking	(6)	(6)
8	Material (material analysis)	(2) (8)	(2) (8)

3.3.1.3.5 - ATG B600

§	Requirements	Admissions tests	Trade control
	Dimensional		
10.1.3	Waterproofing		(10)
5.3	Visual control		(10)
5.3	X-ray inspection: wetted surface and routing (NF A 88-942): for brazed assembly (on one solder of the assembly)	Examination of the qualifications of brazers/ welder - brazers and QMOS	(10)
5.3.3	Macrographic examination of solder solders		(10)
10	Marking		(10)

In the case of applicant/holder manufacturers of several product families (prefabricated fittings/feeders and prefabricated elements), trade control tests on prefabricated fittings cover the monitoring of prefabricated elements.

3.3.1.3.6 - XPE 29-195

§	Requirements	Admissions tests	Trade control
	Dimensional (see particular specification if applicable)	(7)	(7)
5.1	Waterproofing	(7)	(7)
5.2	Load loss	(7)	(7)
5.3	Resistance to hydraulic pressure	(7)	(7)
5.4	Tensile strength	(7)	(7)
5.5	Holds foldability	(7)	(7)
5.6	Penetration resistance	(7)	(7)
5.7	Crush resistance	(7)	(7)
5.8	Wear resistance of the exterior protection (when it exists)	(7)	(7)
5.9	Temperature resistance (if there is a protective sheath)	(7)	(7)
5.10	Resistance to salt spray	(7)	
5.11	Corrosion resistance to hydrochloric acid	(7)	(7)
5.12	Stress corrosion resistance for parts containing copper alloys	(7)	(7)
5.13	Electrical continuity	(7)	
6	Marking	(7)	(7)
7	Packaging and instructions	(7)	(7)

3.3.1.3.7 - SRAC326-NF

§	Requirements	Admissions tests	Trade control
4.1	Waterproofing	(7)	(7)
4.2	Load loss	(7)	(7)
4.3	Tensile strength	(7)	(7)
4.4	Bending resistance	(7)	(7)
4.5	Resistance to thermal cycles	(7)	(7)
4.6	Impact resistance	(7)	(7)
4.7	Crush resistance	(7)	(7)
4.8	Rotation endurance test	(7)	(7)
4.9	Endurance test of the sliding function of the fitting	(7)	(7)
5	Sizing	(7)	(7)
6	Marking	(7)	(7)
7	Packaging and instructions	(7)	(7)

3.3.1.3.8 - CCH 2020-02

§	Requirements	Admissions tests	Trade control
4 and 5	Construction and dimensional requirements	(1)	(6)
6.1	Waterproofing	(9)	(9)
6.2	Resistance to chemical actions	(3) (9)	(4) (9)
6.3	Resistance to mechanical actions	(3) (9)	(4) (9)
6.4	Marking resistance	(6)	(6)
7	Marking	(6)	(6)
8	Installation instructions	(6)	(6)
9	Protection	(6)	(6)

Legend for all the tables in paragraph 3.3.1.3:

- (1) Elements examined by CERTIGAZ during the analysis of the technical file and during audits
- (2) 1 product for each type of manufacturing process (bar turning, stamping/machining and/or foundry/machining).
- (3) For all DN's of nuts (crimped and non-crimped) or sockets to be deformed (for captive nuts)
- (4) For all DN's of crimped nuts or sockets to be deformed (for captive nuts)
- (5) 1 DN of uncrimped nut
- (6) For all products affected by the tests
- (7) For each type of stock and each DN
- (8) Metallurgical analysis by independent laboratory
- (9) 2 models per range
- (10) 1 product for each type of process (brazing and/or brazing) and per brazing and/or brazing site . The verification method in paragraph 4.5 of specification SRAC100-NF can be used as an alternative to the normative tests of standard NF A 88-942

In the case of a common supplier for different certificates and for the same industrial process, the controls can be adapted to cover all products.

In the case of products using common elements, CERTIGAZ may possibly reduce testing by only carrying out the test on a single product or spreading the tests over the different products.

3.3.1.3.9 - NF EN 751-1

§	Requirements	Admissions tests	Trade control
§ 6.2	Verification of technical documents	X	X
§ 5.1.1	Visual aspect	X	X
§ 5.1.2	Chemical Stability	X	X
§ 5.1.3	Anti-corrosion property: - Corrosivity test (classified 3 or less according to EN ISO 2160)	X	X
§ 5.1.4	Storage stability	X	X
§ 7.2.1.1	Preparation of test specimens	X	X
§ 5.2.1.1 + § 7.2.1.2	Effectiveness (leakage)	X	X
§ 5.2.1.2 + § 7.2.1.3	Resistance to gas condensates: - conditioning with n-pentane for 72 hours - then verification Effectiveness	X	X
§ 5.2.1.3 + § 7.2.1.4	Resistance to hot water: - conditioning at 130°C for 168 hours - then verification of effectiveness	X	1 time every 3 years
§ 5.2.1.4 + § 7.2.1.5	Resistance to temperature cycles: - cycles (5 cycles 150°C + 1 cycle -20°C = 124h) - then verification Efficiency	X	X
§ 5.2.1.5 + § 7.2.1.6	Resistance to vibrations: - vibrations for 30 min - then verification Effectiveness	X	X
§ 5.2.2 + § 7.2.2	Compatibility with foaming leak detectors	X	X
§ 8.1	Marking on packaging	X	X
§ 8.2	Instructions	X	X

3.3.1.3.10 - NF EN 751-2

§	Requirements	Admissions tests	Trade control
§ 6.2	Verification of technical documents	X	X
§ 5.1.1	Visual aspect	X	X
§ 5.1.1	Anti-corrosion property	X	X
§ 5.1.3	Storage stability	X	X
§ 5.1.1 + § 7.2.1.1	Wettability / Preparation of test specimens	X	X
§ 5.2.1.1 + § 7.2.1.2	Effectiveness (leakage)	X	X
§ 5.2.1.1 + § 7.2.1.2	Efficiency (leakage) – additional tests if class A	X	X
§ 5.2.1.2 + § 7.2.1.3	Efficiency after orientation adjustment (for Arp class only)	X	X

§	Requirements	Admissions tests	Trade control
§ 5.2.1.3 + § 7.2.1.4	Resistance to gas condensates: - conditioning with n-pentane for 72 hours - then verification Effectiveness	X	X
§ 5.2.1.4 + § 7.2.1.5	Resistance to hot water (class A): - conditioning at 130°C for 168 hours - then verification of effectiveness	X	1 time every 3 years
§ 5.2.1.4 + § 7.2.1.5	Resistance to hot water (class B and C): - conditioning in a water bath at 70°C for 6 hours - then verification of effectiveness	X	
§ 5.2.1.5 + § 7.2.1.6	Resistance to temperature cycles: - cycles (5 cycles 150°C + 1 cycle -20°C = 124h) - then verification Efficiency	X	X
§ 5.2.1.6 + § 7.2.1.7	Vibration resistance	X	X
§ 5.2.2 + § 7.2.2	Compatibility with foaming leak detectors	X	X
§ 5.2.3 + § 7.2.3	Hardening and disassembly	X	X
§ 8.1	Marking on packaging	X	X
§ 8.2	Instructions	X	X

3.3.1.3.11 - NF EN 549 (03/1995)

§	Requirements	Admissions tests	Trade control
§ 6.1	Visual control	X	X
§ 7.2	Hardness	X	X
§ 7.3	Tensile strength and elongation at break	X	X
§ 7.4	Deformation after compression	X	X
§ 7.5	Resistance to aging	X	X
§ 7.6	Gas resistance	X	X
§ 7.7	Resistance to lubricants	X	X
§ 7.8	Ozone resistance	X	X

3.3.1.3. 12 - NF EN 549 (07/2019)

§	Requirements	Admissions tests	Trade control
§ 6.1	Visual control	X	X
§ 7.2	Hardness	X	X
§ 7.3	Tensile strength and elongation at break	X	X
§ 7.4	Deformation after compression	X	X
§ 7.5	Resistance to aging	X	X
§ 7.6	Gas resistance	X	X
§ 7.7	Resistance to the liquid phase or condensates of gaseous fuels	X	X
§ 7.8	Resistance to lubricants	X	X
§ 7.9	Ozone resistance	X	X

3.3.1.3.13 - NF EN 682 and NF EN 682/A1

§	Requirements	Admissions tests	Trade control
§ 4.2.3	Hardness	X	X
§ 4.2.4	Tensile strength and elongation at break	X	X
§ 4.2.5	Residual compression deformation	X	X
§ 4.2.6	Accelerated aging	X	X
§ 4.2.7	Stress relaxation in compression	X	X
§ 4.2.8	Volume change in liquid B	X	X
§ 4.2.9	Volume change in oil	X	X
§ 4.2.10	Ozone resistance	X	X
§ 4.2.11	Residual deformation after compression at -15°C	X	X

3.3.2 Audit

When examining a request for admission to the right to use the NF mark for (interchangeable) fittings, CERTIGAZ carries out an audit of the site(s) taking into account the table below:

Interchangeable fittings and prefabricated fittings (brazing/ welding)			
Entities	Audited industrial processes	Audit frequency	Comments
Product mastery site	All processes	Admission and every year	
Subcontractor	Turning	No site audit	N / A If receipt control + supply control by holder (otherwise, annual audit)
	Stamping / Machining	Forging and machining	Admission and 1 time during the validity period of the certificate If receipt control + supply control by holder (otherwise, annual audit)
	Foundry/machining	Foundry, machining and 100% leak testing	Admission and 1 time during the validity period of the certificate If receipt control + supply control by holder (otherwise, annual audit)
	Nut crimping or socket deformation	Nut crimping or socket deformation (for captive nut)	Admission and 1 time during the validity period of the certificate If batch release tests, reception control + supply control by holder (otherwise, annual audit)
	Brazing	Brazing process + 100% tightness check	Admission and every year
	Soldering	Welding -brazing process + 100% tightness check	Admission and every year
	Stock construction with stainless steel tube	Corrugated or tube manufacturing with longitudinal welding (if applicable) Assembly 100% leak test	Admission and every year

Gas appliance connection kits			
Entities	Audited industrial processes	Audit frequency	Comments
Product mastery site	All processes	Admission and every year	
Subcontractor	Brazing	Brazing	Admission and every year
	Forging/foundry	Forging and foundry	Admission and 1 time during the validity period of the certificate If receipt control + supply control by holder (otherwise, annual audit)
	Tube forming	Forming	Admission and 1 time during the If receipt control + supply control by holder (otherwise, annual audit)

Gas appliance connection kits				
Entities		Audited industrial processes	Audit frequency	Comments
			validity period of the certificate	
	Waterproofing	100% leak test	Admission and every year	
	Nut crimping or socket deformation	Nut crimping or socket deformation (for captive nut)	Admission and 1 time during the validity period of the certificate	If batch release tests, reception control + supply control by holder (otherwise, annual audit)
	Final test	Batch release control and periodic control	Admission and every year	

When examining a request for admission of the right to use the NF mark:

- for threaded connection sealing products, the manufacturing and packaging sites for the sealing products are audited,
- for elastomers, the mixing sites are audited.

The duration of the audit is defined by CERTIGAZ taking into account the complexity of the products and the range presented.

The audit must be carried out taking into account the requirements of paragraph 2.4.3.

In the case of an extension request, CERTIGAZ decides to carry out, if it considers it necessary, an audit to verify that the new provisions implemented by the manufacturer meet the requirements of this standard. In this case, the audit may only relate to certain elements specific to the manufacturing of the product subject to the request.

The purpose of the audit is to ensure that the provisions defined and implemented by the applicant in the audited design and/or manufacturing and/or marketing process meet the requirements of part 2 of this certification framework.

The audit is conducted by adopting the general principles defined in the ISO/IEC 19011 standard for carrying out a quality audit. The scope of the audit and the details of its conduct are specified in an audit plan sent in advance to the company.

In the case of a request where an additional workshop is involved for a significant part of the process, a joint or separate audit is organized.

In the case of maintaining the NF mark for a product, CERTIGAZ carries out an annual audit lasting at least half a day on site. The various packaging control sites must be audited.

In the event that the entity subcontracts part of its activity, CERTIGAZ reserves the right to carry out an audit of the subcontractor(s) based on the same framework.

All means (premises, installations, equipment) allowing the auditor to carry out the mission incumbent on him must be made available to him, as well as the competent people to carry it out.

The inspectors/auditors may, with the applicant's agreement, take a copy of any document they consider necessary.

The applicant accepts the presence of a third-party observer during the audit. If there is a conflict of interest, the holder may challenge the third-party observer.

At the end of the audit, a closing report signed by those present at the closing meeting states the number of non-conformities noted. An audit report is then drawn up by the auditor and sent to the applicant.

The audit report lists possible findings:

- Major non-compliance
- Minor non-compliance
- Sensible point
- Strong point

In the case of non-conformities noted during the audit, the applicant must return to the auditor the non-conformity sheets completed with the corrective actions implemented and their implementation deadline.

The auditor analyzes the corrective actions and their implementation time, then decides on their relevance.

A major non-conformity must be resolved, verification of the effective implementation of corrective actions must be carried out by the auditor. An unresolved major non-compliance blocks the certification process.

When a non-compliance (major or minor) cannot be resolved on the basis of the action plan and the elements provided, it may be necessary to carry out an additional audit. The purpose of this audit is to examine on site the effectiveness of the implementation of corrective actions. The RSC communicates this necessity to the client, explaining the reasons for this decision and indicating the expected duration (0.5 day or 1 day). This eventuality is indicated by the auditor during the closing meeting when presenting the non-conformity(s).

A minor non-compliance must be resolved on the basis of the action plan proposed by the applicant:

- Minor non-compliance can be lifted depending on the action plan and the elements provided
- Minor non-compliance can be lifted during the next audit when it is necessary to verify the effective implementation and effectiveness of the corrective actions

An unresolved minor non-compliance does not block the certification process. Sensitive points should be checked at the next audit.

Exceptional exemption procedure linked to the Covid 19 pandemic:

Admission audits are not permitted remotely.

In the event that carrying out the surveillance audit of a manufacturing site is impossible due to health measures linked to the Covid19 pandemic, the following procedure may apply:

- ▶ This procedure is only applicable if the holder carries out a physical receipt check of the products manufactured on the non-auditable site and the holder's site is audited;
- ▶ The admission audit can be carried out remotely for the holder's site only for sites already audited by CERTIGAZ within the framework of another NF mark managed by CERTIGAZ (NF078, NF115, NF136 or NF404). In this case, the audit must be carried out by an auditor who has already carried out a physical audit on the site concerned;
- ▶ Carrying out a remote audit of the non-physically auditable site with videoconferencing in all sectors of the company (including production workshops). The duration of the remote audit may be increased compared to the duration of a physical on-site audit;
- ▶ Third-party monitoring tests in accordance with the provisions of part 4 of this document but with a periodicity of 3 months, until the physical audit is completed;
- ▶ Carrying out the physical audit imperatively as soon as health measures allow it.

3.4 Evaluation and decision

CERTIGAZ evaluates:

- The audit reports and the auditor's transmission sheets and analyzes the corrective actions and their implementation time, the relevance of the applicant's responses;
- The manufacturer's application and supporting documents;
- Technical files;
- Test reports.

The test results must demonstrate that all product performance complies with the requirements of the standards. Test reports must demonstrate compliance for all tests defined in paragraph 3.3.1.3

In the event of disputed results, CERTIGAZ may request the carrying out of an additional control to verify the implementation of corrective actions (full or partial audit and/or tests).

If CERTIGAZ encounters difficulties in making a decision, the Specific Committee of the NF540 mark may be asked to give an opinion.

Following the evaluation of the results of all the elements, CERTIGAZ makes one of the following decisions:

- ▶ Certification Agreement
- ▶ Refusal of certification

In the event of a positive certification decision, AFNOR Certification grants, through CERTIGAZ, the right to use the NF mark, and CERTIGAZ sends the applicant, who becomes the holder, the NF certificate and the letter notifying the decision.

The certificate issued has a validity period of 3 years. Any reproduction of this certificate must be made in its entirety.

In the event of breaches linked to safety obligations and in the absence of specified requirements, CERTIGAZ may pronounce, without delay, as a precautionary measure, the necessary decision to refuse certification.

The applicant may contest the decision taken by sending a request, in compliance with the General Rules of the NF mark.

The granting of the right to use cannot in any way substitute the responsibility of CERTIGAZ for that which legally falls to the company holding the right to use the NF mark.

The terms of communication on certification are defined in part 2.5 of these Certification Rules.

Part 4

MAKING CERTIFICATION LIVE: monitoring methods

Throughout the duration of the certification, the holder must:

- Comply with the defined requirements and marking procedures described in part 2,
- Update their certification file as provided for in part 7,
- Systematically inform CERTIGAZ of any change in one of the characteristics of the certified product, and/or its organization likely to have an impact on certification.

In addition, CERTIGAZ reserves the right to carry out any checks (visits, tests, verifications, etc.) that it considers necessary following:

- a modification concerning the certified product or the quality organization of the manufacturing entities (manufacturing factory, manufacturing workshops, subcontractor factory, etc.);
- to complaints, disputes, litigations, etc., ... of which he is aware and relating to the use of the NF Mark.

Certified products are monitored annually by CERTIGAZ upon granting the right to use the NF mark .

Generally speaking, during any visit and in all locations, whatever the main purpose of his mission, the NF inspector/auditor inquires about the use made of the NF mark and all questions relating to the application of the General Rules of the NF mark and these Certification Rules.

4.1 Monitoring methods

Monitoring of NF certified products includes product testing and audits of the manufacturing site(s).

It also concerns the monitoring of the use of the mark and logo on products, packaging and all communication media.

Monitoring methods are defined below but can be a function:

- decisions taken following previous controls,
- possible complaints.

4.1.1 Tests on the NF certified product

4.1.1.1 General

The conformity tests of the certified product are carried out in accordance with the specifications of the admission tests defined in paragraph 3.3.1 in an independent laboratory or in the manufacturer's NF authorized laboratory depending on availability and choice of the holder.

In the case of certified products using common elements, CERTIGAZ may possibly reduce testing by only carrying out the test on a single product or spreading the tests over the different products.

The quantities to be taken are those cited in the applicable standards and specifications and are defined by CERTIGAZ in particular cases.

Surveillance tests are carried out annually in accordance with the provisions of paragraph 3.3.1.

Samples are taken from the manufacturer's stock. The cost of these withdrawals remains the responsibility of the latter.

In the absence of a sufficiently representative stock (in quantity or date of manufacture), samples can be taken from a distributor or in the store with the purchase costs re-invoiced to the manufacturer. In this case, the holder is informed before the withdrawal.

In the absence of production since the last sampling or since certification, the monitoring sampling may be postponed at the request of the holder. Over a period of 3 years, there must be at least one surveillance test report.

In this case, any debit deferral must be requested in writing from CERTIGAZ by the holder, by email or on letterhead.

Failure to comply with this obligation, as well as any false declaration, noted by CERTIGAZ may lead to a suspension or even withdrawal of the right to use the NF mark.

Regardless of the sanctions that may be taken within the framework of surveillance and the continuation of the normal control rhythm, any negative control of a product may lead to the carrying out of a new control.

4.1.2 Audit of the manufacturing site

Audits are carried out periodically to ensure compliance with the conditions specified in paragraphs 2.4. The frequency of audits of fittings manufacturing sites are defined in the table in paragraph 3.3.2.

For threaded connection sealants, the sealing product manufacturing and packaging sites are audited annually.

For elastomers, the mixing sites are audited annually.

The conditions of completion are the same as the initial audit. The duration of the audit is generally one day but can be reduced or increased depending on the complexity of the product, the range of products monitored and the size of the manufacturing site.

If the holder manufactures products under several NF applications mandated to CERTIGAZ, the surveillance audit can be joint to several marks; in this case the duration of the audit is adapted and a team of auditors can be mandated.

The management of audit findings is identical to that of the admission or extension audit (see § 3.3.2).

A major or minor non-compliance must be resolved on the basis of the action plan proposed by the applicant:

- Non-compliance can be lifted based on the action plan and the elements provided
- The non-compliance can be lifted during the next audit when it is necessary to verify the effective implementation and effectiveness of the corrective actions

In the case of maintaining the NF mark for a product, CERTIGAZ carries out a surveillance audit every 2 years.

4.2 Evaluation and decision

The evaluation procedures are similar to those for admission described in part 3.

Depending on the results of all the verifications, CERTIGAZ can decide :

- to renew the certification,
- to renew the certification with one (or more) observation(s), to renew the certification with one (or more) warning(s) and with or without additional control(s),
- to pronounce the suspension of certification
- to pronounce the withdrawal of certification,

Reconduction :

CERTIGAZ sends a reconduction letter confirming the surveillance carried out, after receipt of the results of surveillance tests and the results of the audit(s).

By this certification reconduction decision letter issued by CERTIGAZ, AFNOR Certification reconducts the right to use the NF mark.

Renewal :

Before the end of the certificate's validity date, CERTIGAZ evaluates the results of the surveillance (audits and tests) and any sanctions imposed, then decides on the renewal of the certification.

Suspension:

In the event of breaches linked to safety obligations and in the absence of specified requirements, CERTIGAZ may pronounce, without delay, as a precautionary measure, the necessary suspension decision.

The suspension decision:

- specifies the terms of its lifting. The lifting procedures may be specified or reviewed by CERTIGAZ based on the expertise, analysis of the causes and corrective actions presented by the holder.
- is pronounced for a period of 6 months, renewable under conditions; the total duration of a suspension cannot exceed 2 years. After this period, a withdrawal decision will be made by CERTIGAZ.

The suspension may be lifted before the expiry date indicated in the decision letter from CERTIGAZ if the terms of its lifting are respected.

In the event of suspension or withdrawal of certification, AFNOR Certification suspends or withdraws the right to use the NF mark

The sanction is enforceable from the date of receipt of its notification.

Additional verification costs caused by the sanctions are the responsibility of the holder.

The holders are responsible for the right to use the NF mark relating to the product in question and undertake to apply the measures resulting from the suspension or withdrawal of the right to use, taken in accordance with these Certification Rules.

Any suspension or withdrawal of the right to use the NF mark results in a ban on using the NF mark and referring to it for any new production (See paragraph 4.4). For manufacturing prior to the suspension or withdrawal of the right to use, CERTIGAZ, on a case-by-case basis, may take specific measures (example: authorization to dispose of stocks, destruction of stock, recall of products, etc.)

The holder may contest the decision taken by sending a request in accordance with the General Rules of the NF mark.

4.3 Declaration of modifications

This chapter specifies the information to be provided and the procedures to follow in the event of modifications concerning:

- The holder
- The production entity(ies)
- The quality organization of the design and/or manufacturing and/or marketing process
- The product

Any modification to the initial conditions for obtaining the NF mark must be reported in writing to CERTIGAZ by the holder.

Failure to comply with this obligation noted by CERTIGAZ may lead to suspension or even withdrawal of the right to use the NF mark.

In cases not provided for in parts 4.3.1 to 4.3.5, CERTIGAZ determines whether the modifications call into question the certification and whether there is a need to carry out an additional check.

Depending on the results of the investigation, CERTIGAZ makes the appropriate decision.

4.3.1 Modification concerning the holder

The holder must notify CERTIGAZ in writing of any legal modification of his company or any change of company name.

In the event of merger, liquidation or absorption of the owner, all rights to use the mark from which he may benefit cease automatically.

A new application can be filed and its examination can be simplified depending on the modifications made.

4.3.2 Modification concerning the production entity(ies)

Any transfer (total or partial) of the production entity(ies) of an NF certified product to another place of production results in an immediate cessation of NF marking by the holder on the products transferred in whatever form.

The holder must declare this transfer in writing to CERTIGAZ who will organize a visit to the new production site and, if necessary, may have tests carried out.

If CERTIGAZ considers that the modifications are important, a request must be communicated to CERTIGAZ by the holder. According to the declared modification, CERTIGAZ determines whether it is a request for extension, admission or maintenance of certification.

The procedures for evaluating and deciding on certification are identical to those for admission described in part 3.

4.3.3 Modification concerning the quality organization of the manufacturing and/or marketing process

The holder must declare in writing to CERTIGAZ any modification relating to its quality organization likely to have an impact on the conformity of manufacturing and/or marketing with the requirements of these Certification Rules (modifications concerning its installations, its quality plans, his agent...).

If CERTIGAZ considers that the modifications are important, a request must be communicated to CERTIGAZ by the holder. According to the declared modification, CERTIGAZ determines whether it is a request for extension, admission or maintenance of certification.

On the other hand, any temporary cessation of internal control of an NF certified product results in an immediate cessation of its NF marking by the holder in any form whatsoever. The holder informs CERTIGAZ.

The procedures for evaluating and deciding on certification are identical to those for admission described in part 3.

4.3.4 Modification concerning the NF certified product

Any modification of the NF certified product in relation to the application file, the accepted model, the Rules defined in the certification framework likely to have an impact on the conformity of the product with the requirements of this certification framework or any change of commercial brand must be the subject of a written declaration to CERTIGAZ.

According to the declared modification, CERTIGAZ determines whether it is a request for extension, admission or maintenance of certification.

4.3.5 Temporary or permanent cessation of production

Any definitive or temporary cessation of manufacturing of an NF certified product or any abandonment of a right to use the NF mark must be declared in writing to CERTIGAZ, indicating the desired length of time for the stock of NF marked products to be sold. .

Upon receipt of the holder's letter, CERTIGAZ notifies the holder of the suspension of the right to use the NF mark . The maximum stock flow date is defined by CERTIGAZ based on the holder's demand and the market relating to the product.

The withdrawal of the right to use the NF mark is notified upon expiry of the stock clearance period indicated by the holder, which has previously been approved by CERTIGAZ ; the product is then removed from the list of certified products.

During the sale of stock, the annual management and the right to use the NF mark must be paid.

4.4 Conditions for stopping marking or demarking in the event of suspension, withdrawal or abandonment

Any suspension or withdrawal of the right to use the NF RAC-GAZ mark results in a ban on using this mark and making reference to it. Likewise, accidentally non-compliant products must be marked down.

Consequently, in these cases, the NF mark must no longer appear on the products, their packaging, documentation, advertising or any other support from the manufacturer.

Part 5

STAKEHOLDERS

The organizations involved during the procedure for issuing the right to use the NF mark and the monitoring of NF certified products are specified below.

5.1 AFNOR Certification

AFNOR is the owner of the NF mark and has granted AFNOR Certification an exclusive operating license.

AFNOR Certification manages and runs the NF certification system, which notably defines the governance rules and operating procedures for the NF mark.

AFNOR Certification 11, rue Francis de Pressensé F-93571 THE PLAIN SAINT-DENIS CEDEX	Telephone: +33 (0)1 41 62 80 00 Marque-nf@afnor.org www.marque-nf.com
---	---

5.2 CERTIGAZ

In accordance with the General Rules of the NF mark, AFNOR Certification entrusts the management of the NF RAC-GAZ mark to the following organization, known as the mandated organization:

CERTIGAZ 1, rue du Général Leclerc 92800 Puteaux	Telephone: +33 (0)1 80 21 07 40 infocertigaz@certigaz.fr www.certigaz.fr
---	--

CERTIGAZ is responsible to AFNOR Certification for the operations entrusted to it and which are the subject of a contract.

5.3 Inspection and audit organization

The audit functions of the manufacturing unit, and possibly at the places of use, are provided by CERTIGAZ

In certain cases, audit and inspection operations can be carried out by a subcontractor qualified by CERTIGAZ.

The auditors have the right to inspect any applicant or holder as part of their mission.

5.4 Laboratories

When the controls carried out include tests on products, these are carried out at the request of CERTIGAZ by the following laboratory(ies), known as the mark's laboratory(ies):

Laboratory	Contact
CETIAT (TECHNICAL CENTER FOR AERAUPLICS AND THERMAL INDUSTRIES) BP 2042 F-69603 VILLEURBANNE CEDEX	Tel. : +33 (0)4 72 44 49 00
CETIM 74 Route de la Jonelière 44300 NANTES	Tel. : +33 (0)2 40 37 36 35
ELANOVA 60 rue Auber94408 VITRY SUR SEINE CEDEX	Tel. : +33 (0) 1 49 60 57 57

Testing laboratories wishing to carry out tests as an independent laboratory will apply to CERTIGAZ. They will be appointed on a proposal from CERTIGAZ after consultation with the Specific Committee. These laboratories must meet the criteria defined by the NF EN ISO/CEI 17025 standard.

5.5 Special committee

5.5.1 Role and missions of the Special Committee

A consultative organization called the Special Committee has been set up, the secretariat of which is provided by CERTIGAZ.

The Special Committee meets periodically or when necessary. The missions of this Committee are to give an opinion on:

- all questions relating to the certification of gas connections on request from CERTIGAZ,
- developments in the Certification Rules (expanding the scope of application, technical developments, etc.). The Committee then assesses the impact of the changes and proposes a transition period if necessary.
- certification files on request from CERTIGAZ (including dispute resolution, sanctions, etc.),
- approve the minutes of the meetings of the Special Committees.
- participates in the system for preserving impartiality (§5.2 of standard NF EN ISO/CEI 17065)

The draft texts and changes to these Certification Rules are submitted for the opinion of the Special Committee before their approval by AFNOR Certification. The consultation is carried out by CERTIGAZ which processes the various opinions of interested parties and provides them with feedback. CERTIGAZ prepares the final text, taking into consideration everyone's opinions and tending to reconcile divergent opinions.

The Special Committee is a consultative organization which issues opinions serving as a basis for decisions. Consensus is systematically sought.

CERTIGAZ may decide not to follow the advice of the Special Committee, for example if it is contrary to accreditation obligations. In this case this decision and the reasons for this decision must be recorded.

The members of the Committee cannot receive any remuneration for the functions entrusted to them.

CERTIGAZ takes special measures to ensure the confidentiality of applicant or holder files presented within the Special Committee (except in the event of dispute/appeal).

To do this, a commitment to confidentiality and impartiality is provided by each full or alternate member.

Representatives of AFNOR Certification, the ministry and CERTIGAZ are bound by confidentiality within the framework of their functions and do not disclose this commitment.

For specific subjects, the Committee may call on an expert. He is then invited and by signing the attendance list, like any participant, he undertakes to maintain the confidentiality of the information discussed during the session.

The Special Committee may entrust some of its work to working groups. The result of this work will be presented to the Special Committee for opinion.

These working groups may be composed of members of the Special Committee and holders of the NF mark.

Before each meeting, CERTIGAZ sends an agenda to each member, accompanied or not by preparatory documents.

During each meeting of the Special Committee, CERTIGAZ presents the complaints/appeals received and takes stock of Cofrac accreditation. CERTIGAZ also presents the actions put in place to manage the risks of conflicts of interest. The Special Committee gives its opinion on the methods put in place by CERTIGAZ to control its impartiality. This opinion is recorded in the minutes.

CERTIGAZ writes and sends the report to the members of the Committee.

5.5.2 Composition of the Special Committee

The composition of the Special Committee is set in such a way as to respect a representation between the different parties concerned which does not lead to the predominance of one of them and which guarantees their relevance.

The members of the Special Committee are designated by CERTIGAZ. A member of the Special Committee may only be represented by a substitute designated under the same conditions.

During meetings of the Special Committee, the holder and his deputy may be present, but in the event of a vote, only the holder may speak.

When several incumbent manufacturers belong to a group, only one seat is possible for the group. However, the Committee member and his or her alternate may belong to two different entities within the same group and participate in meetings together.

The term of office of the members and the president is 3 years. This mandate is renewable by tacit agreement if there are no other applications and the maximum number of seats per college is not reached.

The Committee is made up of three colleges:

College of MANUFACTURERS:

3 to 10 seats representing manufacturers holding the NF RAC-GAZ mark.

College of USERS/PRESCRIBERS:

3 to 10 seats representing users/prescribers

- (Gas distributors, professional union of gas companies, installers, sanitary heating dealers, GSB Large DIY Stores, consumers, etc.).

College of TECHNICAL ORGANIZATIONS AND ADMINISTRATION:

3 to 10 seats representing technical and administrative organizations

- (AFNOR Certification, BNG, CERTIGAZ, independent laboratories of the NF RAC-GAZ mark, technical inspection organization, Ministry in charge of gas safety, etc.).

The President of the Special Committee is appointed from among the members of the Special Committee and by them.

CERTIGAZ and AFNOR Certification are ex officio vice-presidents.

Part 6

THE RATES

The purpose of this part is to define the amount of services relating to NF certification and to describe the recovery methods.

NF certification includes the following services:

- Development and implementation of an application
- Instruction of the request
- How the certification application works
- Trials
- Inspection/audit visits
- Levy
- Right to use the NF mark
- Additional controls
- Promotion

6.1 Services relating to certification

Nature of the service	Definition of the service	General conditions common to NF marks
Development and implementation of an application (Registration)	Participation in the implementation of the application of the NF mark including the development of the Rules (reference) for certification	A registration fee is paid by the applicant upon first request for the right to use the NF mark. This right is invoiced from the registration by CERTIGAZ of the first request and at the latest at the time of invoicing of the right of use (during product certification).
Instruction of the request	Service including examination of application files, relations with applicants, laboratories, inspectors/auditors, evaluation of control results	Payment of the amount of these services remains acquired even if the right to use the NF mark is not granted or if the application is abandoned during processing.
How the certification application works	Services for managing files of certified products and holders, establishing lists of certified products, evaluating control results.	This management is invoiced annually at the start of the year. Upon admission, management is calculated pro rata for the months following the certification decision. Management of the NF mark remains acquired even in the event of withdrawal or suspension during the year.
Trials	Laboratory testing services.	Prices for the tests provided by the laboratories and which ensure the invoicing of this service.

Nature of the service	Definition of the service	General conditions common to NF marks
Inspection and audit visit	Services including preparation for the visit, the visit itself as well as the visit report. In addition to these services, travel costs and packages related to long-distance travel are added.	Payment of these services remains acquired even if the right to use the NF mark is not granted or renewed.
Levy	Service including preparation and the collection itself.	The service is billed based on actual time spent.
Right to use the NF mark	This usage right paid to AFNOR Certification contributes: <ul style="list-style-type: none"> • in defense of the NF mark: registration and protection of the mark, legal advice, handling of appeals and abusive uses (justice services). • to the generic promotion of the NF mark. • the general functioning of the NF mark (management of NF mark governance organizations, quality systems, etc.). 	The amount of the usage fee is invoiced by CERTIGAZ, and paid to AFNOR Certification as manager and facilitator of the NF certification system. Upon admission, the usage fee is calculated pro rata for the months following the certification decision. The right to use the NF mark remains acquired even in the event of withdrawal or suspension during the year.
Additional controls	Services resulting from additional controls or verification tests which may prove necessary following inadequacies or anomalies detected by routine controls.	Services payable by the applicant/holder.
Promotion	Sectoral promotion actions for the NF mark.	Fee whose amount can be defined each year and invoiced in addition to other services.

6.2 Recovery of services

The services defined above are invoiced by CERTIGAZ to the applicant/holder.

CERTIGAZ is authorized to recover all services.

However, the organizations involved in the trials invoice and collect directly the amount of the corresponding services,

The applicant or holder must perform these services under the prescribed conditions: any failure on the part of the holder in fact hinders the exercise by CERTIGAZ of the control and intervention responsibilities incumbent upon it under these Rules Certification (repository).

Payment of invoices issued by CERTIGAZ is due within 30 days of receipt of the invoice, or upon receipt in the case of invoices addressed to a foreign manufacturer.

In the event that a first formal notice does not determine payment of the entire sums due, any sanction provided for in part 4 may be taken for all of the holder's admitted products.

The services billed correspond to the number of checks carried out. Any additional audit or testing is billed to the manufacturer, regardless of the results obtained.

As long as stocks of NF marked products remain with the holder, controls are maintained as well as reimbursement of the corresponding services.

6.3 Amount of services

The amount of these services and the right to use the mark are subject to a financial regime that is revised annually by CERTIGAZ and sent, at the beginning of the year, to all owners of the mark, to the members of the Special Committee and to AFNOR Certification.

This price is available on request from CERTIGAZ and on the CERTIGAZ website: www.certigaz.fr

Prices are in Euros excluding taxes. When it comes to testing rates, samples must be delivered to the mark's laboratory, carriage paid and cleared where applicable, within a maximum period of 15 days from the date of collection.

Part 7 CERTIFICATION FILES

7.1 Right to use application file

The request for the right to use the NF mark must be sent to CERTIGAZ.

In the event that the request comes from an entity located outside the European Economic Area or outside the European Free Trade Association (EFTA), the applicant appoints a French representative who co-signs the request.

The applicant establishes a file whose content must be adapted on a case-by-case basis :

- ⇒ Letter of request (admission, extension or maintenance) reproduced on the applicant's letterhead and established according to the attached model, *(see model letter 001 and 002)* ,
- ⇒ General information sheet, *(see Sheets 003)* ,
- ⇒ Product sheet, *(see Sheets 004)* ,
- ⇒ Technical file. *(see Sheet 005)* .

	Request for NF certification		
	Admission	Extension	Maintenance
Letter of request and commitment	Standard letter 001	Standard letter 002 A	Standard letter 002 B
A general information sheet concerning the applicant – Sheet 003: - 003 A: standard - 003 B: if agent	X	If modification compared to the product already certified	If modification compared to the product already certified
Product sheet 004: - 004 connection (1) - 004 elastomer - 004 sealants -004 gas appliance connection kits (1) -004 prefabricated sets (1)	X	If modification compared to the product already certified	X
Technical file Sheet 005	X	X	If modification compared to the product already certified

(1) The type 004A connection sheet is an Excel file available on the website www.certigaz.fr

7.2 Form models

STANDARD LETTER 001 NF RAC-GAZ MARK
--

**REQUEST FORM FOR THE RIGHT TO USE THE NF MARK
OR EXTENSION OF THIS RIGHT FOR A NEW PRODUCT (ADMISSION)
(to be established on applicant's letterhead)**

**CERTIGAZ
Madam/Mr. Director General
1, rue du Général Leclerc
92800 Puteaux**

Subject: **NF RAC-GAZ mark**
Request for admission of the right to use the NF mark for a new product

<Madam/Sir> the Director General,

I have the honor to request the right to use the NF mark for the following product/range of products:

<product designation/normative reference document>

manufactured in the following manufacturing entity:

<company name + address>

and for the brand and for the following reference:

<trademark and commercial reference>

To this end, I declare that I know and accept the General Rules of the NF mark, as well as the NF RAC-GAZ Certification Rules and undertake to respect them throughout the duration of use of the NF mark, all these rules, available on the CERTIGAZ website and supplied on request by CERTIGAZ

I undertake to pay, upon receipt of the invoices, the costs which are our responsibility. Prices are available on the CERTIGAZ website and can be requested from CERTIGAZ

<OPTION (1): I also authorize the Company (company name), (status of the company), (head office) represented by Mr./Ms./Ms. (name of legal representative) as (capacity) to represent me on French territory for all questions relating to the use of the NF RAC-GAZ mark in accordance with the mandate attached to this request.

I undertake to immediately notify CERTIGAZ of any change in the representative designated above.

<OPTION: I request in this regard that the services which are my responsibility be invoiced directly to him.

She will ensure payment on my behalf and in my name, upon receipt of the invoices as she undertakes to do by accepting the representation.

Please accept, Madam/Mr. Director General, my distinguished greetings.

**Date and signature
of the legal representative
of the applicant (required)**

**<OPTION (1): Date and signature
of the representative in the EEA / EFTA>**

(1) Only concerns applicants located outside the European Economic Area and the European Free Trade Association

**STANDARD LETTER 002 A
NF RAC-GAZ MARK**

**REQUEST FORM FOR EXTENSION OF RIGHT TO USE THE NF MARK
FOR A MODIFIED PRODUCT
(to be established on applicant's letterhead)**

**CERTIGAZ
Madam/ Mr. General Manager
1, rue du Général Leclerc
92800 Puteaux**

**Subject: NF RAC-GAZ
Request for extension of the right to use the NF mark for a modified product**

<Madam/Sir> the Director General,

As the holder of the NF mark for the product of my manufacture identified under the following references:

- . product name/product range:
- . normative reference document:
- . manufacturing entity: (*<company name> <address>*)
- . brand and commercial reference:
- . certificate number: (*number*)
- . right of use granted on: (*date of certificate*)

I have the honor to request the extension of the right to use the NF mark for the product of products of my manufacture, deriving from the product already certified NF **<certificate no. RAC>** by the following modifications: **<stated changes>**.

This product/product range replaces the certified product: NO YES

I declare that the products/range of products which are the subject of this request are, for other characteristics, strictly in conformity with the products/range of products already NF certified and manufactured under the same conditions.

To this end, I declare that I know and accept the General Rules of the NF mark as well as the NF RAC-GAZ Certification Rules and undertake to respect all these Rules, available on the CERTIGAZ site and provided on request by CERTIGAZ.

I undertake to pay, upon receipt of the invoices, the costs which are our responsibility. Prices are available on the CERTIGAZ website and can be requested from CERTIGAZ.

Please accept, Madam/Mr. Director General, my distinguished greetings.

**Date and signature
of the legal representative
of the owner**

**STANDARD LETTER 002 B
NF RAC-GAZ MARK****REQUEST FORM FOR MAINTAINING THE RIGHT TO USE THE NF MARK FOR A NEW COMMERCIAL
MARK AND/OR SPECIFIC REFERENCE
(to be established on applicant's letterhead)**

**CERTIGAZ
Madam/Mr. Director General
1, rue du Général Leclerc
92800 Puteaux**

Subject: **NF RAC-GAZ**
Request to maintain the right to use the NF mark

<Madam/Sir> the Director General,

I have the honor to request the maintenance of the right to use the NF mark for the product(s) which differ(s) from the NF certified product only by its (their) references and/or the mark commercial which are affixed there and by arrangements which in no way modify their characteristics.

This request concerns:

- the designation of the product/product range
- the manufacturing unit : (<company name> <address>)
- the right of use granted on: (date of certificate)
- the certificate number : (number)

The commercial name requested by the distributor is:

- commercial reference:
- trademark :

I declare that the product(s) which are the subject of this request is/are, for other characteristics, strictly in conformity with the product(s) already certified NF and manufactured (s) under the same conditions.

To this end, I declare that I know and accept the General Rules of the NF mark as well as the NF RAC-GAZ Certification Rules and undertake to respect all these Rules, available on the CERTIGAZ site and provided on request by CERTIGAZ.

I undertake to pay, upon receipt of the invoices, the costs which are our responsibility. Prices are available on the CERTIGAZ website and can be requested from CERTIGAZ.

Please accept, Madam/Mr. Director General, my distinguished greetings.

**Date and signature
of the legal representative
of the applicant**

**(and signature of the holder of the NF RAC-GAZ mark
for agreement in the case of a maintenance request
where the applicant is different from the holder)**

**<OPTION (1): Date and signature
of the representative in the EEA/EFTA>**

(1) Only concerns applicants located outside the European Economic Area and the European Free Trade Association

**LETTER TYPE
SHEET 003 A
NF RAC-GAZ MARK**

GENERAL INFORMATION SHEET CONCERNING THE APPLICANT / HOLDER

MANUFACTURING UNIT :

- Social reason :.....
-
- Address :
-
- Country :.....
- Tel. :
- SIRET number (1): APE code (2):
- Fax: / Email, website:
- Name and capacity of the legal representative (3):
- Name and position of the correspondent (if different):
- Quality system certification:

APPLICANT / HOLDER (if different from the manufacturing unit) :

- Social reason :.....
-
- Address :
-
- Country :.....
- Tel. :
- Fax: / Email, website:
- Name and capacity of the legal representative (3):
- Name and position of the correspondent (if different):

REPRESENTATIVE IN THE EEA (if requested) :

- Social reason :.....
-
- Address :
-
- Country :.....
- Tel. :
- SIRET number (1): APE code (2):
- Fax: / Email, website:
- Name and capacity of the legal representative (3):
- Name and position of the correspondent (if different):

(1) and (2) Only for French companies.
 (3) The legal representative is the legal person responsible for the company.

**SHEET 003 B
NF-RAC-GAZ MARK**

STANDARD LETTER FOR PROXY

AUTHORITY IN THE EEA:

Mr. Director General,

- Social reason :

.....
.....

- Address :

.....
.....
.....

- Country: - Tel: - Fax:

.....

- SIRET number (1): NAF code (1):

.....

- Name and capacity of the legal representative (2):

.....

- Name and position of the correspondent (if different):

.....

I authorize the Company identified above as agent to represent me on French territory for all questions relating to the use of the NF RAC-GAZ mark. I undertake to immediately notify CERTIGAZ of any new appointment of the representative designated above.

In this regard, I request that the costs which are my responsibility be invoiced directly to him. She will ensure payment on my behalf and in my name, upon receipt of the invoices as she undertakes to do by accepting the representation.

Please accept, Mr. Director General, the expression of my distinguished consideration.

<p>Date, name and signature of the legal representative (2) of the applicant/holder preceded by the handwritten note " <i>Good for representation</i> "</p>	<p>Date, name and signature of the agent in France preceded by the handwritten note " <i>Good for acceptance of the representation</i> "</p>
--	---

(1) Only for French companies.

(2) The legal representative is the person legally responsible for the company.

SHEET 004 Elastomer

PRODUCT SHEET

- Product identification / mixture number:

.....
.....
.....
.....

- Product definition standards:

.....
.....

- Tradename :

- trademark :

- commercial reference:

- Specific characteristics:

Nominal hardness:

Temperature class:

Ozone resistance:.....

Others :

SHEET 004 Sealing products

PRODUCT SHEET

- Product identification / identification number:

.....
.....
.....
.....

- Product definition standards:

.....
.....

- Tradename :

- trademark :

- commercial reference:

- Specific characteristics:

Class :

Others :

SHEET 005
NF RAC-GAZ MARK

TECHNICAL FILE MODEL

The technical file must consist of at least the elements below. It can be supplemented in particular by quality plans, control plans, a quality manual.

The elements of the technical file are organized in the order defined below.

This file can be communicated to CERTIGAZ in computer format (in PDF format) on the condition that all these elements are contained in a single PDF file.

- 1 – Overall plans
- 2 – Nomenclature (if necessary)
- 3 – Detailed plans of all components (taking care to precisely define the materials used)
- 4 – Marking plan
- 5 – Definition of the coding of the batch number indicated on the certified product
- 6 – Instructions (installation, use, as applicable)
- 7 - Conditioning
- 8 – Approval certificate or test report for elastomers (in particular if compliance with standard NF EN 549 is requested)
- 9 – Certificate of conformity of the materials used (certificate type document 3.1 of standard NF EN 10204)
- 10 – If brazing or welding : welding notebooks, descriptions of operating procedures, qualifications of operating procedures, inspection instructions, qualification of welders/brazers

**STANDARD LETTER 00 6
NF RAC-GAZ MARK****REQUEST FORM FOR NF MARKING OF PRODUCTS IN STOCK WITH THE HOLDER
(to be established on applicant's letterhead)****CERTIGAZ
Madam/Mr. Director General
1, rue du Général Leclerc
92800 Puteaux****Subject: NF RAC-GAZ
Request for NF marking of products in stock**

<Madam/Sir> the Director General,

I, the undersigned, "*name and responsibility of the signatory*"; representing the company "*name of applicant / holder*", requests to benefit from an evaluation of the stocks of NF RAC-GAZ certified products present in my unit of "*identity and address*" with a view to marking of the products manufactured before the decision to certification.

"I hereby affirm that the manufacturing of the products present in the stocks, and for which a request for stock assessment is to be made, was carried out under the same conditions as the manufacturing corresponding to the products certified under certificate no. ° (same processes, same suppliers, same design, same quality system and control plan....) »

Or

"I hereby declare that the products in stock at the time of certification were manufactured on sites not covered by the product certification but that the definitions and materials are identical to those of the certified products"

I undertake to make available to the auditor all documents enabling the traceability and conformity of products in stock to be proven (control reports, material certificates, traceability documents, quality documents, etc.)

Please find attached the summary table, dated "..././..." specifying at least for each reference and batch number in stock, the elements listed in the certification rules.

I noted that CERTIGAZ will communicate its decision on the results of this evaluation and that any marking of batches in stock is prohibited before the decision is pronounced.

To this end, I declare that I know and accept the General Rules of the NF mark as well as the NF RAC-GAZ Certification Rules and undertake to respect all these Rules, available on the CERTIGAZ site and provided on request by CERTIGAZ.

I undertake to pay, upon receipt of the invoices, the costs which are our responsibility. Prices are available on the CERTIGAZ website and can be requested from CERTIGAZ.

Please accept, Madam/Mr. Director General, my distinguished greetings.

**Date and signature
of the legal representative
of the applicant****<OPTION (1): Date and signature
of the representative in the EEA/EFTA>**

(1) Only concerns applicants located outside the European Economic Area and the European Free Trade Association

Part 8

GLOSSARY

Abandonment:	The holder requests the cessation of the right to use the mark on all or part of its products.
Agreement for the right to use the NF mark:	Authorization granted by AFNOR Certification and notified by CERTIGAZ to an applicant, to affix the NF mark on the product for which the application was made. This agreement is materialized by a certificate.
Audit:	According to the NF EN ISO 9001 standard: Part of the site visit relating to the examination of a product and assessment of the specific means implemented to ensure its compliance with the requirements set out in the certification framework.
Warning :	Decision taken by the certification organization by which the holder must correct the shortcomings. Sanction decision, notified by CERTIGAZ, by which the holder is asked to correct the defects noted, during which the right to use the NF mark is not suspended.
Consensus:	According to the NF EN 45020 standard: General agreement characterized by the absence of firm opposition to the essence of the subject emanating from a significant part of the interests at stake and by a process of seeking to take into consideration the views of all the parties concerned and reconciliation of possible divergent positions. Note: Consensus does not necessarily imply unanimity.
Request :	Letter by which an organization requests the right to use a certification mark, declares that it knows and undertakes to respect the certification reference system in its entirety.
Applicant:	Legal entity requesting certification and which undertakes to control the conformity of its product to the certification framework in question.
Right to use the NF mark:	Right granted by AFNOR Certification to an organization to use the NF mark for products in accordance with the General Rules and the relevant NF certification reference system.
Extension :	Authorization granted by AFNOR Certification and notified by CERTIGAZ to an applicant, to affix the NF mark on the modified product for which the application was made. This agreement is materialized by a certificate. This procedure by which a file from an applicant for certification is examined, and which comes from a holder, concerns a product already admitted to the mark and subject to modifications or a new product deriving from a product already admitted to the mark.
Batch :	A batch is a set of products, of the same model, manufactured during the same manufacturing campaign. By manufacturing campaign we mean the period during which a defined and homogeneous quantity of products is manufactured under uniform conditions. The batch is defined and marked by the manufacturer.

Maintenance:	Authorization granted by AFNOR Certification and notified by CERTIGAZ to an applicant, to affix the NF mark on an already certified product for which the modification does not require any technical examination (example: change of reference or commercial brand; aesthetic modification without functional impact....).
Representative :	Legal or natural person established in the EEA who has a function of representing the applicant/holder outside the EEA and has a written mandate from the latter meaning that he can act in his name for any question relating to the use of the NF mark, the certification process and invoicing. The agent can be the distributor or the importer, his different functions are clearly identified.
Major non-compliance	Deviation from a requirement of the framework affecting the organization, application or formalization of the QMS, product or process (manufacturing/control, etc.) and leading to a proven risk (i.e. based on objective elements) of non-compliance, recurring or single in the event of a very significant risk, of a specified requirement, linked to the safety of the product
Minor non-compliance	Deviation from a standard requirement affecting the organization, application or formalization of the QMS or process (manufacturing/control, etc.) and not leading to a significant risk of non-compliance with a specified requirement not linked to the product.
Strong point	Point which exceeds the requirements of the benchmark, or particularly efficient
Admissibility:	Status of a file which allows the request to be processed; admissibility concerns the administrative parts of the file.
Reconduction:	Decision by which the holder has their the right to use the NF mark reconducted in the context of surveillance.
Renewal :	Decision by which the holder has their right to use the NF mark renewed.
Withdrawal :	Decision taken by the certification organization which cancels the right to use the NF mark. Withdrawal may be pronounced as a sanction or in the event of abandonment of the right of use by the holder.
Suspension:	Decision taken by the certifying organization which cancels for a specific period the right to use the NF mark. Suspension may be imposed as a sanction or in the event of temporary abandonment by the holder.
Holder :	Legal entity which benefits from the right to use the NF mark.
Manufacturing unit:	Factory ensuring the manufacture of products covered by the Standard as well as responsibility for final testing and inspection of the products.